



RESEARCH ARTICLE

ORGANIZATIONAL INNOVATION AND INFORMATION AND COMMUNICATIONS TECHNOLOGY (ICT): STRATEGIC, ADMINISTRATIVE AND QUALITY INNOVATION IN HIGHER EDUCATION INSTITUTIONS

Minerva Martínez Ávila, *Eréndira Fierro Moreno and Joel Martínez Bello

Universidad Autónoma del Estado de México, Facultad de Contaduría y Administración

ARTICLE INFO

Article History:

Received 25th April, 2016
Received in revised form
24th May, 2016
Accepted 20th June, 2016
Published online 31st July, 2016

Key words:

Information and Communications Technology (ICT), Organizational innovation, Strategic innovation, Administrative innovation, Qualityinnovation.

ABSTRACT

The objective of this study is to determine the mediating effect of strategic innovation, administrative innovation and quality innovation between Information and Communications Technology (ICT) and organizational innovation. Using a cross-sectional design, with a sample of 32 institutions of higher education in Mexico through its medium level managers and administrative staff perception. Using statistical technique of structural equation modeling (SEM) and relying on the resource based view we found support for the hypotheses. The results confirm the mediating effect of strategic innovation, administrative innovation and innovation quality between ICT and organizational innovation. This study provides empirical evidence to manage the organizational innovation taking into account involved and mediating variables in the relationship.

Copyright©2016, Minerva Martínez Ávila et al. This is an open access article distributed under the Creative Commons Attribution License, which permits unrestricted use, distribution, and reproduction in any medium, provided the original work is properly cited.

Citation: Minerva Martínez Ávila, Eréndira Fierro Moreno and Joel Martínez Bello, 2016. "Organizational innovation and information and communications technology (ICT): Strategic, administrative and quality innovation in higher education institutions", *International Journal of Current Research*, 8, (07), 35339-35348

INTRODUCTION

Several authors have theoretically addressed to organizational innovation, whether to identify structural features as to analyze their effects on products, processes of innovation, creativity and organizational change; or in how organizations emerge and develop as well as how its members learn (Linton, 2002; Tang, 1998; Lawrence, 1954; Greiner, 1967; Argyris and Schön, 1978; Levy and Merry, 1986). Organizational innovation and Information and Communications Technology (ICT) are seen as the miracle of postmodernism in organizations, assuming that they should solve most problems of the organization, in an efficient and quick way (Jbilou, Landry, Amara and Adlouni, 2009). Actually, innovation can be considered as a basic resource in the prosperity of nations and technology (Ruiz and Mandado, 1989). In addition, it is considered that innovation is an intangible resource of great importance in corporate strategy (Wu and Lin, 2011). An organization must innovate to

demonstrate its uniqueness in order to maintain their competitive advantage (Barney, 1991). Innovation refers to the explanation to modify or develop a new idea, product or service, procedures, policies and ways of doing different things that generate changes and competitive advantages (Hansen and Birkinshaw, 2007; Robbin, 1996). Under this argument research was based on the resource based view, where organizations that have a combination of tangible and intangible resources generate benefits to the organization by being inimitable and irreplaceable (Grant, 1991; Penrose, 1959; Wernerfelt, 1995; Barney, 1991; Bontis, 1999). In Higher Education Institutions (HEI), the ICT forms a new type of rapport, being fundamental in the management of schools, teaching, research, and dissemination of art, science and university extension; that is, they are tools that are engaged in the process of technological change (Gómez, Martínez, Demuner, 2013). HEI in Mexico, being in a technological transition as part of the internationalization of higher education is inescapable the study of innovation processes influenced by ICT. Several empirical evidences confirm that educational innovation supported by the Information and Communications Technology is now considered a worldwide priority (Bocconi, Kampylis and Punie, 2013; Law, Yuen, Fox, 2011).

*Corresponding author: Eréndira Fierro Moreno,
Universidad Autónoma del Estado de México, Facultad de Contaduría y Administración

Multiple studies have addressed a number of factors in the process that leads to the adoption of innovation such as ICT, organizational structure, communication, change, leadership, adoption and diffusion of innovation, among others (De Pablos, Colás, González, 2010; Daft, 1978). However, it were not found empirical evidences that jointly study the strategic innovation, management innovation and quality innovation between ICT and organizational innovation in Higher Education Institutions (HEI). Based on the above argument, the **objective** of the research is: determine the mediating effect of strategic innovation, management innovation and quality innovation between ICT and organizational innovation; in order to answer three interrelated questions: First, to what extent the strategic innovation, management innovation and quality innovation mediates the relationship between ICT and organizational innovation?; Second, what is the effect of ICT on strategic innovation, management innovation and quality innovation?; Third, how influences the strategic innovation, management innovation and quality innovation on the organizational innovation?

This research contributes to broaden the scope of knowledge of organizational innovation in Higher Education Institutions (HEI) by the following contributions: first, strategic innovation, management innovation and innovation quality are variables that mediates the relationship between Information and Communications Technology and organizational innovation; second, empirical evidence notes that the Information and Communications Technology have a positive impact in the strategic innovation, management innovation and quality innovation; third, the administrative innovation and quality innovation have a positively influence in the organizational innovation. The document has the following structure. First, a literature review, then the research method, later the results and the structural model were presented; and it was completed with the findings, discussion, limitations and implications of the research.

Literature review and hypothesis

There are several empirical evidences that have addressed organizational innovation (e.g. Zahara, Belardino and Boxx, 1988; Khan and Manopichetwattana, 1989, Damanpour, 1991; Ashraf and Asif, 2013) and the relationship of the Information and Communications Technology with the organizational innovation (Jbilou, Landry, Amara and Adlouni, 2009; Duivenboden and Thaens, 2008; Anderson, 2006). In addition, research on innovation has had a significant increase sponsored by educational reforms that intend to change existing objectives and educational practices; but also it is considered and it is remembered that these innovations can be influenced by ICT (Nachmias, Mioduser, Cohen, Tubin, and Forkosh-Baruch, 2004; Law, Chow and Yuen 2005; De Pablos, Colas and Gonzalez 2010). The use of ICT has brought about a major transformation at all levels of the organization, being the innovation activity one of the beneficiaries (Jimenez Martinez and Gonzalez, 2008). Research by Bond and Houston (2003), Prasad, Ramamurthy and Naidu (2001) agree that ICT is a competitive advantage by being able to boost innovation processes and be considered as strategic tools.

It is noteworthy that although there are several empirical studies have addressed the impact of innovation and Information and Communications Technology (ICT) in public, private and educational organizations, it have not been found scientific evidences that examine the relationships of this study.

The effect of Information and Communications Technology in the strategic innovation

The Information and Communications Technology and strategic innovation as strategic resources are key elements in the direction of higher education organizations, as they give greater value to creativity and the capacity to innovate (Maldonado, 2007). Several studies have addressed the subject of strategic innovation (Markides, 1997; Utterback, 1994 among others). Strategic innovation refers to creating new products, services, production methods, supplies, organizational approaches and technological innovation to create an added value or improve the performance of the management of the organization as a corporate strategy (Wu and Lin, 2011; Zahra and Bogner, 2000; Johannessen, Olsen and Lumpkin, 2001). Daft (1978) divided the strategic innovation between the technological innovation and organizational innovation. Betz (2011) considers to the technological innovation within the process innovation, products and services; as a technological invention. Lester (1988), Adams, Bessants, Phelps (2006), Rothwell (1992), Kleinschmidt and Cooper (1995) consider that to implement strategic innovation successfully, it must have to consider five aspects: first, provide guidelines for facing strategic issues; second, strategically plan projects that yield an advantage as an innovative projects; third, to be in practical and continuous learning for materialize the benefits of successful innovations; fourth, work on radical and incremental innovations; fifth, planning portfolio research and development with teams involved in innovative projects simultaneously. Hamel (1996), Kim and Mauborgne (1997), Markides and Anderson (2006) and Porter (1996) conceptualize the strategic innovation as the discovery of a different strategy in an organization to remain competitive, it is considered as an important resource in the development of the organizations. There are some important factors that can influence the implementation of innovative strategies such as leadership, time, resources, luck, but certainly, nowadays a factor influencing strategic innovation are the Information and Communications Technology, for being key tools in implementing new strategies (De Pablos, Colas, Gonzalez, 2010, Salinas, 2004). It is also considered that without strategic innovation the competitive vision of organizations would be unlikely (Markides and Anderson, 2006). That is, strategic innovation occurs when an organization identifies areas in a sector that may allow them to create and serve new segments and new needs that have not been met by competitors through innovative strategies with the use of ICT, by the important role of ICT on strategic innovation (Moheno, Valles and Campos, 2009; Hamel, 1996). Based on the above arguments, the following hypothesis was established in this study.

H1: The Information and Communications Technology has a positive impact on strategic innovation.

The effect of Information and Communications Technology (ICT) on administrative innovation

From the point of view of Damanpour (1991), administrative or technical innovation emphasizes the organizational structure and in the administrative processes related to basic activities of the work within the organization, it focuses on services, products and technological processes. And it is in these activities where the use of ICT has brought about a major transformation at all levels of the organization (Jimenez Martinez and Gonzalez, 2008). Research by Bond and Houston (2003), Prasad, Ramamurthy and Naidu (2001) agree that ICT is a competitive advantage by being able to boost innovation processes and be considered as strategic tools. Information and Communications Technology as technological tools can provide efficient and low cost services in organizations through innovative processes in the management of services, resources and operations (Jazkyte, 2012). Thereby, the Information and Communications Technology can be leveraged to address many organizational problems in an innovatively way, benefiting organizations in their daily activities (Pinho and Macedo 2006). Based on the above argument, the following hypothesis is raised.

H2: The Information and Communications Technology has a positive impact on administrative innovation.

The effect of Information and Communications Technology (ICT) on quality innovation

Information and Communications Technology could play an important role for organizations as a platform to drive quality innovation (Anderson, 2006). In education, universities need to enter into processes of quality improvement; it is considered that innovation processes supported by ICT, is a key factor of development (Salinas, 2004). Quality innovation is the accumulation of all the results of innovation; it include quality of products and services, the quality of the process of corporate operations, quality of management. The quality of innovation indicates how an organization strives to search for the innovation of new products, processes or management methods. When the result of innovation satisfies the parties of interest, such as customers, employees, suppliers, among others, it means that innovation has quality (Wu and Lin 2011; Haner, 2002). Ontiveros (2008) considers that the Information and Communications Technology can contribute to the generation of quality innovation, by modifying products and processes; considering that an organization could not stop to make use of them, as these permeate all organizational areas. Based on the above theoretical argument, it is set the hypothesis:

H3: Information and Communications Technology has an influence on quality innovation.

The effect of strategic innovation, administrative innovation and quality innovation on organizational innovation

Decisions on strategic innovation are integrated into a strategy formulation process, where strategies must be aligned with the

overall strategy of the organization in a manner consistent (Chen and Yuan, 2007); in relation to administrative innovation, which involves administrative aspects and the social system of the organization (Daft, 1978; Damanpour, 1991) while, the quality innovation is generated by the satisfaction of the expectations of users and clients in the process, products or services (Wu and Lin 2011). Nowadays organizations will have to make use of the different ways so that it can be generate organizational innovation; these forms are the processes of internal and external research and development; through the search for new strategies, new organizational structures and new administrative processes (Cassiman and Veugelers, 2006; Chen and Yuan, 2007; Navarro, Aranguren and Magro, 2012). Therefore, the HEI to boosting the processes of strategic innovation, the administrative innovation and the quality innovation are likely to generate some profit competitive strategy in the organization.

Given these arguments the following hypotheses were established:

H4: Administrative innovation has a positive influence on organizational innovation.

H5: Quality innovation have a positive impact on organizational innovation.

H6: Strategic innovation affects positively organizational innovation.

The mediating effect of strategic innovation, administrative innovation and quality innovation between organizational innovation and Information and Communications Technology

Innovation is an important organizational strategy that has been studied by several researchers. Wu and Lin (2011) conducted a study to explore the relationship between strategic innovation, quality innovation and organizational innovation, finding a positive and significant impact on the different relationships. At the same time, it is essential to consider that the Information and Communications Technology plays an increasingly important role in promoting education and driving innovation (OECD, 2010) paper. There are several empirical evidences that support that the Information and Communications Technology has great potential to allow creative processes that generate organizational innovation (Craft, 2005; Loveless, 2008). The Information and Communications Technology and innovation are often seen as interrelated concepts; under which these technologies are a catalyst for organizational innovation (Duivenboden and Thaens, 2008). Therefore, it is possible to assume that strategic innovation, administrative innovation and the quality innovation mediate the relationship between organizational innovation and Information and Communications Technology. Under this argument, the following hypothesis is planned:

H7: Strategic innovation, administrative innovation and the quality innovation mediate the relationship with the organizational innovation through Information Communications Technology.

Operational definition of variables

Organizational innovation (dependent variable) is a process of development, adoption and implementation of new ideas to generate new products, changes, practices, processes, policies, creativity or services for the organization (Milhim and Schiffauerova, 2013, Comeaux, 2013; Wu and Lin 2011; Damanpour and Evan 1984; Daft 1978). Through innovation, organizations adapt and diversify, and even rejuvenate or "reinventing" to adapt to the changing conditions of the Information and Communications Technology and the market (Vazquez, Santos and Alvarez 2001). This organizational innovation variable has been operationalized with four items.

Information and Communications Technology (independent variable) are tools or strategic resources that drive innovation processes through a transformation at all levels of the organization and are formed by a set of devices associated with computers, internet and telecommunications, among others (Calderon, Nunez, Laccio, Lannelli, Gil, 2015; De Pablos, Colas and Gonzalez 2009; Jimenez Martinez, Gonzalez, 2008; Bond, Houston, 2003; Prasad, Ramamurthy and Naidu 2001).

The integration of Information and Communications Technology in recent decades has been one of the most significant changes and social impact on organizations by being constantly evolving. Access to information was one of the greatest difficulties in education, with the advent of ICT available information is abundant and the challenge is to know how to handle, process and interpret; they can become powerful tools that facilitate management in the HEI, even they are accessible in emerging countries (Calderon, Nunez, Laccio, Lannelli, Gil, 2015). The measurement of the variable of Information and Communications Technology has been operationalized with five items. The organization must disseminate the objectives of strategic innovation and specify niche markets, to establish strategies and structures for its implementation (Aagaard, 2012). Strategic innovation (mediating variable) are corporate strategies that are made through a process of realization of a completely new and different idea, which includes the generation of a new concept, innovation of products, processes, services and the management for an approach to new markets, strategic innovation can lead to growth, performance and competitive advantages (Wu and Lin, 2011; Zahra and Bogner, 2000; Johannessen, Olsen and Lumpkin, 2001; Porter, 1996). This variable has been operationalized with five items. Daft (1978) in the "Dual-Core" model divides innovation into two areas: administrative innovation and technical innovation. Administrative innovation (mediating variable) consist in the adoption of new administrative management systems and human resources, which includes rules, roles, procedures, administrative processes, organizational structure affecting the social system, organizational communication and the environment (Vijande and Gonzalez 2008; Damanpour, 1991; Damanpour and Evan, 1984; Daft, 1978). This variable has been operationalized through four items. Quality innovation (mediating variable) is the set of all results of organizational innovation that includes the quality of products and services, the quality processes current corporate operations, as well as the quality of management; when innovation satisfies the interest parties such as clients, users, employees and suppliers, then it means that innovation is of "quality"; so that innovation

quality can be evaluated according to the institutional purpose and results of the organization, such as the renewal of processes and modernized approach work (Wu and Ling 2011; Haner, 2002). This variable has been operationalized six items. Ahmed and Mohamed (2000) consider that quality innovation should include three aspects: 1) quality products and services, cost reduction, yields to invest and perceived value by customers; 2) quality in the operation process, timely deliveries with cash personnel; 3) quality management that understands the needs of customers for the innovation of products and services and success rates in innovation by creating patents.

Method

The design of the study that was used to verify the hypothesis above was not experimental, transversal, with a quantitative approach. Regarding the hypotheses to be tested, was a correlational study that made use of the multivalent modeling technique structural equation (SEM), which allows to evaluate multiple simultaneous relationships and move from the exploratory analysis to the confirmatory (Hair, Anderson, Tatham and Black, 2008; Lévy and Varela, 2006).

Sample

To test the hypotheses, meet the objective and to answer research questions was carried out a process of convenience sampling in 32 Higher Education Institutions (HEI) of the State of Mexico, with a sample of 235 middle managers (area coordinators) and administrative staff; who are an essential part of the daily activities of educational institutions. The results indicated that 55% of respondents were women and that the greatest number of respondents ranged from age 40 to 49 years, representing 36.6%.

Instrument

Data were collected by applying a written instrument self-administered, made from the theoretical contributions of several authors. To measure the independent variable organizational innovation, was taken as a reference to Milhim and Schiffauerova (2013), Comeaux (2013), Wu and Lin (2011), Damanpour and Evan (1984), Daft (1978); the independent variable of Information and Communications Technology, was supported by Calderon, Nunez, Laccio, Lannelli, Gil (2015); De Pablos, Colas and Gonzalez (2010); Jimenez Martinez, Gonzalez (2008); Bond, Houston, 2003; Prasad, Ramamurthy and Naidu (2001); the mediating variable, strategic innovation by Aagaard (2012); Wu and Lin (2011); Zahra and Bogner (2000); Johannessen, Olsen and Lumpkin (2001); Porter (1996); the mediating variable, administrative innovation by Vijande and Gonzalez (2008), Damanpour (1991); Damanpour and Evan (1984); Daft (1978) and the mediating variable, quality innovation by Wu and Ling (2011); Haner (2002) and Admed and Zaire (2003). The instrument was integrated into two sections: the first contains demographic and organizational data; the second contains the items to measure the five variables studied (organizational innovation, strategic innovation, administrative innovation, quality innovation and the use of Information and Communications Technology).

Table 1. Descriptive statistics and correlation (n = 235)

Variable	Mean	Standard deviation	ICT (1)	SI (2)	AI (3)	QI (4)	OI (5)
(1) ICT (Information and Communications Technology)	4.42	.96	(.974)				
(2) SI (Strategic innovation)	4.55	1.08	.740**	(.940)			
(3) AI (Administrative innovation)	4.27	1.06	.679**	.502**	(.956)		
(4) QI (Quality innovation)	4.28	1.05	.697**	.516**	.474**	(.931)	
(5) OI (organizational innovation)	4.08	1.09	.563**	.632**	.565**	.380**	(.963)

Nota **. The correlation is significant at level 0.01 (bilateral).
The alpha of Cronbach's of each variable is observed parenthetically.

Table 2 presents the coefficients standardized and not standardized, standard error, significance and R²; which shows that all coefficients are significant (p < 0.001).

Table 2. Factorial load and R²

Variables	Unstandardized coefficients	Standardized coefficients	Standard error	P Significance	* R ²
Organizational innovation					0.481
18	1.000	0.742	0.080	***	0.551
20	1.113	0.871	0.081	***	0.759
21	1.172	0.931	0.080	***	0.867
22	1.061	0.831	0.082	***	0.690
Strategic innovation					0.486
1	1.000	0.895	0.042	***	0.801
2	0.927	0.928	0.040	***	0.861
3	0.907	0.920	0.040	***	0.846
4	0.913	0.897	0.043	***	0.805
5	0.833	0.832	0.047	***	0.693
Administrative innovation					0.461
8	1.000	0.896	0.048	***	0.785
9	1.028	0.920	0.050	***	0.847
10	0.987	0.850	0.056	***	0.722
13	0.780	0.662	0.067	***	0.438
Quality innovation					0.547
30	1.377	0.833	0.165	***	0.694
31	1.566	0.894	0.182	***	0.799
32	1.597	0.966	0.186	***	0.803
33	1.440	0.806	0.175	***	0.650
36	1.059	0.609	0.150	***	0.371
39	1.000	0.521	0.150	***	0.271
Information and Communications Technology					
45	1.143	0.841	0.076	***	0.707
46	0.997	0.841	0.066	***	0.708
47	1.115	0.886	0.068	***	0.786
48	1.090	0.85	0.071	***	0.726
49	1.000	0.81	0.065	***	0.654

*** (p < 0.001).

R² It is an index that tells us the proportion of variance of the indicator that manages to be explained by the variables/s that affects it/them (Lévy and Varela, 2006).

Table 3. Convergent validity, discriminant and kindness of measures of model adjustment

Latent variables	Convergent validity ^a	Discriminant validity ^b				
		Organizational innovation	Strategic innovation	Administrative innovation	Quality innovation	ICT
Organizational innovation	0.90	(0.57)				
Strategic innovation	0.95	0.285	(0.80)			
Administrative innovation	0.90	0.377	0.555	(0.72)		
Quality innovation	0.90	0.395	0.379	0.356	(0.60)	
ICT	0.92	0.364	0.394	0.370	0.503	(0.71)
Goodness of fit measures						
Degrees of freedom	246					
X ²	599.03					
X ² /GL	2.435					
RMSEA	0.078					
NFI	0.888					
CFI	0.930					
IFI	0.931					
Pratio	0.891					
PCFI	0.829					
PNFI	0.791					

^a Convergent Validity is calculated using the formula: (sum of standardized weights)² / (sum of standardized weight)² + (sum of error of measurement of the indicator).

^b The values shown in parentheses are the extracted variance of each construct (Hair, Anderson, Tatham & Black, 2008).

Table 4. Direct and indirect effects (Total effects)

Variables	Direct effects	Indirect effects	Total effects
	ICT(Information and Communications Technology)	ICT(Information and Communications Technology)	ICT(Information and Communications Technology)
SI (Strategic innovation)	.697	.000	.697
AI (Administrative innovation)	.679	.000	.679
QI (Quality innovation)	.740	.000	.740
OI (Organizational innovation)	.000	.563	.563

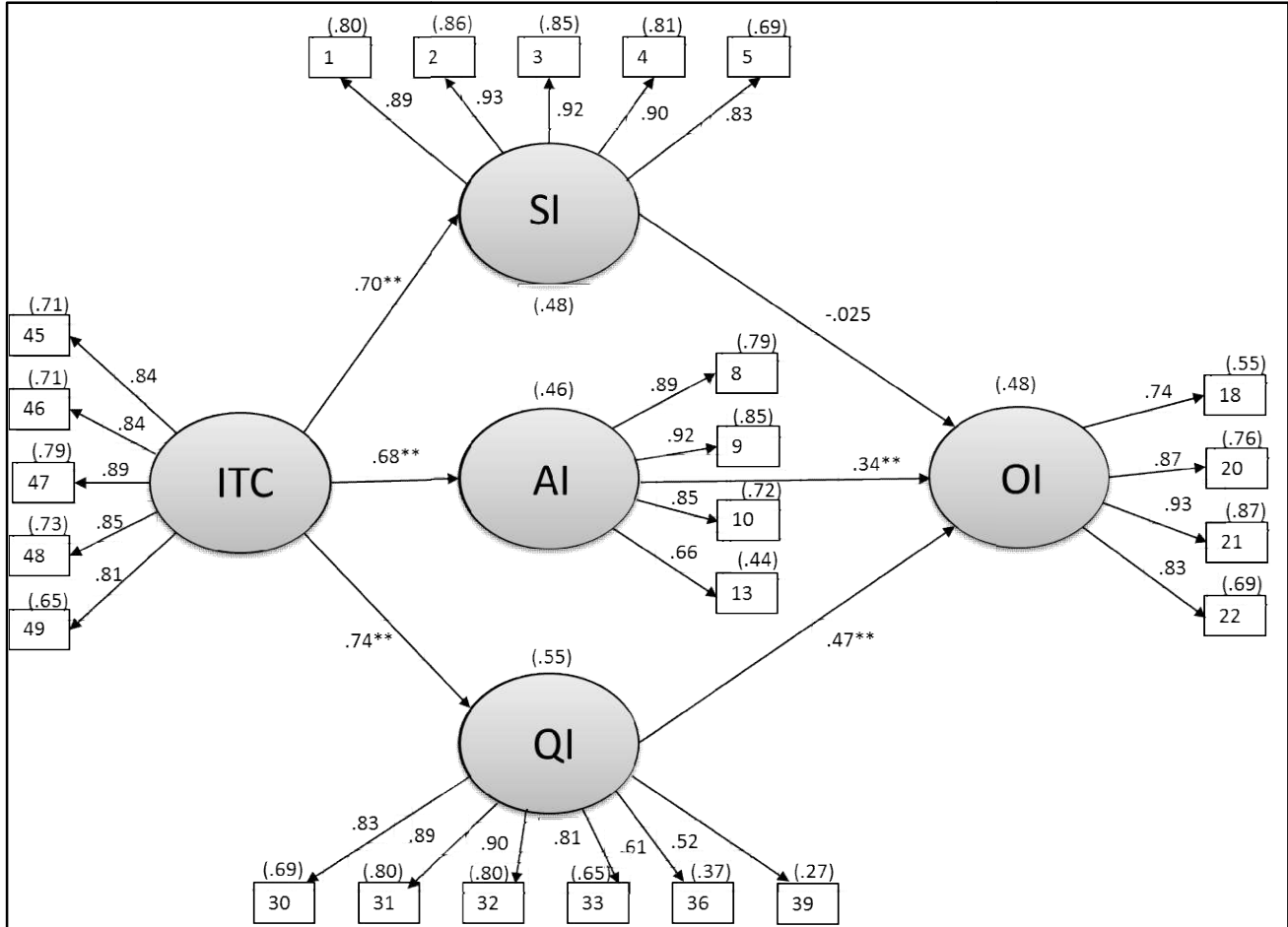

Note: The variance explained is in brackets
 **Significance p<0.001

ICT: Information and Communications Technology
 SI: Strategic innovation
 AI: Administrative innovation
 QI: Quality innovation
 OI: Organizational innovation

Figure 1. Structural model

To improve the quality and refinement of the measurement of the questionnaire, it was submitted to content validation by experts who gave their suggestions and contributions which were incorporated. Subsequently, a pilot test was conducted to establish the relevance of the faculties of the analysis unit 32 people (administrative, media and managerial staff), leaving the final instrument composed of 54 reagents.

Reliability of the instrument

The reliability of the instrument involves generating the same results each time it is administered to the same individual.

The statistical test to validate the internal consistency was Cronbach's alpha; strategic innovation had a Cronbach's alpha of .940, administrative innovation had a .956, organizational innovation had .963, and quality innovation had .931, the Information and Communications Technology had 0.974; very close to unity values, indicating that in this test the internal consistency were proper.

Exploratory factor analysis

Within the exploratory factor analysis the index sampling adequacy Kaiser-Meyer-Okin (KMO) was calculated. This

statistic is evaluated within a range of 0 and 1; it was considered an acceptable value between 0.80 and 0.90; reporting from this study a KMO = 0.951. The Bartlett test of sphericity; that contrast the null hypothesis that the correlation matrix is an identity matrix, proved this significant test $p = .000$; allowing a good sampling adequacy and proper correlation between the reactants. Within the exploratory factor analysis, the factor structures obtained consider five factors, showing all reactive loads or greater than 0.5 saturation criterion from which are considered acceptable (Castañeda and Cabrera, 2010); and explained variance of 74.83%.

Confirmatory factor analysis

To validate the measurement scale of the constructs, it conducted a confirmatory factor analysis of reagents to ratify the model obtained in the exploratory, using the method of maximum likelihood estimation to analyze the correlation matrix. Among the various measures of goodness of fit most commonly used to check the fit of the model, it is X^2 divided by the degrees of freedom; although as proposed by different experts to evaluate the fit between the theoretical model and the observed, does not seem correct to use only this test, since it is affected by the sample size (Bollen, 1989; Hayduck, 1987; Lévy and Varela, 2006). In this analysis the most commonly used indices were determined; chi square ($X^2 = 599.03$, with 246 degrees of freedom; $X^2 / GL = 2.435$), the Mean Square Error of Approximation (RMSEA = .078), the Normed Index Adjustment (NFI = .888), the Index Adjustment Compared (CFI = .930) Incremental Adjustment Index (IFI = .931), the Index Goodness of Fit (GFI = .831) which implies a proper fit in the measurement model.

Estimation procedure

The technique of structural equation modeling (SEM) was used to verify the hypotheses. This technique is an extension of several multivariate techniques such as multiple regression and factor analysis which enables simultaneously examine a number of dependency relationships. That is, it is the most efficient technique for series of simultaneous estimates equations by multiple regression. It involves two components: (1) the structural model and (2) the measurement model. The measurement model allows the researcher use several variables (indicators) for a single variable dependent or independent. In this model, the researcher can assess the contribution of each item of the scale as well as incorporate how the scale measured the concept (reliability) in the estimation of variables. Meanwhile the structural model is the "guide" model, which relates independent variables and dependent variables (Lévy and Varela, 2006). As shown in Table 1, the correlation coefficient of ICT and innovation strategy is 0.740, implying a moderate and statistically significant correlation, so the other variables are in this moderate range, with a bilateral significance 0.01.

Table 3 presents information on convergent validity, discriminant and goodness of adjustment measures. Analysis of the validity convergent and discriminant was proposed by Campbell and Fiske (1959) with the aim of establishing conceptual and empirical evidences for construct validity.

Convergent validity coefficients relate to correlations between measures of a same construct using different methods; while the discriminant validity refers to the correlations between different constructs. To test the construct validity, correlations concerning the validity convergent must be greater than 0.85, while referring to the discriminant validity should be less than 0.50 (Lévy and Mangin, 2000). Also, the average variance extracted is a measure of convergent validity, whose value cannot be less than 0.50 (Fornell and Larcker, 1981). It is observed that the model has convergent and discriminant validity. Also, the model adjustment measures are adequate.

Figure 1 the results of the structural model used to test the hypotheses of the study; where all the factorial loadings, except the relationship between strategic innovation and organizational innovation, were statistically significant ($p < 0.001$) and greater than 0.34. According to the indices of absolute fit, incremental and parsimony, the model is considered acceptable.

Figure 1 a structural relationship between the Information and Communications Technology (ICT) and strategic innovation is positive and significant ($\gamma = .70$; < 0.001). This result supports the hypothesis 1. Figure 1 also shows that the Information and Communications Technology has a significant effect with administrative innovation ($\gamma = .68$; < 0.001), which also supports the hypothesis 2. In addition, Information and Communications Technology presented a positive and significant impact with the quality innovation ($\gamma = .74$; < 0.001), these data support hypothesis 3. The structural relationship between administrative innovation and organizational innovation is positive and significant ($\beta = 0.34$; $p < 0.001$); this result provides support to the hypothesis 4. Similarly the quality innovation has a positive and significant impact with organizational innovation ($\beta = 0.47$; $p < 0.001$). However, strategic innovation had no significant effect with organizational innovation ($\beta = -.025$; $p > 0.005$), so it does not support a hypothesis 6.

The hypothesis 7 predicts that strategic innovation, administrative innovation and quality innovation mediate the influence of Information and Communications Technology (ICT) on organizational innovation. As shown in Table 4, the Information and Communications Technology, as long as innovation strategy, administrative innovation and quality innovation are present, they influence in organizational innovation, because the direct effect of ICT on organizational innovation was statistically not significant. Also, removing the direct effect of Information and Communications Technology (ICT) on organizational innovation an indirect effect on organizational innovation was presented, as shown in Table 4; these data support hypothesis 7.

DISCUSSION

Organizational innovation has been considered as a complex process involving the generation of new ideas and finding new working methods, techniques or instruments; considering that by generating new innovative ideas, they should be promoted and supported to seek their approval and implementation as a

useful transformation process. The theoretical argument of the supported research in the theory of resources and capabilities in where the organizations that have a combination of tangible and intangible resources generate benefits to the organization by being inimitable and irreplaceable could be corroborated, as certain capacities (strategic innovation, innovation administrative, quality innovation and ICT) —intangible capabilities by being managed and, therefore, for being unique in organizations generate new capacities, in this case organizational innovation. This research, which had as its object of study the Higher Education Institutions (IES) and aim to determinate the mediating effect of strategic innovation, administrative innovation and quality innovation between ICT and organizational innovation, could prove the influence of certain variables in the organizational innovation, provided ICT are present. Therefore, ICT allow to introduce changes in different areas of the organization directly impacting organizational innovation, this relationship was verified by Huang, Che, Hashem, Fariyah and Son, 2013. This research evidence the transcendence of the strategic innovation, administrative innovation and quality innovation as mediators in the relationship of ICT and organizational innovation. Among the main findings of this study are, in the first place, the mediating effect of strategic innovation, administrative innovation and quality innovation between ICT and organizational innovation, whereby it is achieved of the objective and the main question of the investigation; secondly, the structural relationships of ICT with strategic innovation, administrative innovation and quality innovation, were positive and significant; thirdly, the ratio of administrative innovation with quality innovation, and the relationship of the quality innovation and organizational innovation were also positive and significant. Overall, the results corroborate the hypotheses; except the hypothesis 6 that was not accepted; one reason could be that the organization has not established in a suitable form strategies and structures that boost organizational innovation from the point of view of strategic innovation. From the foregoing, it is possible to consider that the strategic innovation, administrative innovation, quality innovation and Information and Communications Technology are an issue that should be of interest to managers of higher education institutions as an essential component for to be generated within the organization the organizational innovation, which implies effectiveness and efficiency in organizations (Fierro, Mercado and Cernas, 2013; Jbilou, Landry, Amara and Adlouni, 2009). In summary, the results obtained confirm the mediating effect of strategic innovation, administrative innovation and quality innovation on organizational innovation supported by the Information and Communications Technology, under the theoretical perspective of the theory of resources and capabilities that the investigation argues. That is, the theory used is confirmed, because to the extent that organizations have unique, valuable, different and irreplaceable resources than other organizations, new capabilities will be generated, in this case, in the organizational innovation.

Institutions of Higher Education of the State of Mexico should pay attention not only to the use of ICT in the educational processes and administrative management, but should seek to generate the organizational innovation through other

capabilities such as strategic innovation, administrative innovation and quality innovation.

Limitations of the study and suggestions

This study was based on transversal cutting data. It is suggested to use in future investigations longitudinal designs. It is proposed to apply this type of study to directors, professors and administrative staff with ages under 40 years, in order to observe the impact of ICT when used in generations that use in their majority these technologies. Another limitation is the sample size, which recommends considering carefully the conclusions of this investigation. The findings should be *interpreted carefully when they are generalized*.

REFERENCES

- Aagaard, A. 2012. The Contribution of Innovation Strategy Development and Implantation in Active Facilitation of Pharmaceutical Front Innovation. *Journal Systemic Practice & Action Research*, (25), 457-477.
- Adams, R., Bessant, J. and Phelps, R. 2006. Innovation management measurement: a review. *International Journal of Management Reviews*, 8(1), 21-47.
- Ahmed, P. and Mohamed, Z. 2000. Innovation. A Performance Measurement Perspective in Tidd, J. (Ed). *From Knowledge Management to Strategic Competence: Measuring Technology, Market and Organizational Innovation*. London: Imperial College Press.
- Anderson, J. 2006. Creativity is not enough: ICT-enabled strategic innovation. *European Journal of Innovation Management*, 9(2). 129-148.
- Argyris, C. and Schön D. 1978. *Organizational learning: A theory in action perspective*. Addison-Wesley. USA: Reading.
- Ashraf, F. and Asif, K. 2013. Organizational Innovation and Organizational Effectiveness among Employees of Cellular Companies. *Pakistan Journal of Psychological Research*, 28(1) 01-24.
- Barney, J. 1991. Firm Resource and Sustained Competitive Advantage. *Journal of Management*, 17(1), 99-120.
- Betz, F. 2011. *Managing Technology Innovation: Competitive Advantage from Change*. USA: library of Congress.
- Bocconi, S., Kampylis, P. and Punie, 2013. Framing ICT-enabled Innovation for Learning: The case of one-to-one learning initiatives in Europe. *European Journal of Education*, 48(1), 113-130.
- Bollen, K. A. 1989. *Structural equations with latent variables*. New York: John Wiley & Sons.
- Bond, III. and Houston, M.B. 2003. Barriers to Matching New Technologies and Market Opportunities in Established Firms. *Journal of Product Innovation Management*, 20(2), 120-135.
- Bontis, N. 1999. Managing Organizational Knowledge by diagnosing intellectual capital: framing and advancing the state of the field. *International Journal Technology Management*, 18(5/6/7/89), 433-463.
- Calderon, S.E., Nuñez, P., Di Laccio, J.L., Lannelli, L. M. and Gil, S. 2015. Classroom-laboratories inexpensive, using ICT. *Eureka magazine Teaching and Dissemination of Science*, 12 (1), 212-226.

- Cambell, D.T. and Fiske, D.W. 1959. *Convergent and Discriminant Validation by Multitrait-Multimethod Matrix*. Psychological Bulletin, 56(2), 81-105.
- Cassiman, B. and Veugelers, R. 2006. In Search of Complementary in Innovation Strategy: Internal R&D External Knowledge Acquisition. *Management Science*, 52(1), 68-82.
- Castañeda, M.B. and Cabrera, A.F. 2010. *Procesamiento de datos y análisis estadísticos utilizando SPSS*. Brasil: edipucrs.
- Chen, Y. and Yuan, Y. 2007. The innovation strategy of firms: empirical evidence from the Chinese high-tech industry. *Journal of Technology Management in China*, 2(2), 145-153.
- Comeaux, E. 2013. Rethinking Academic Reform and Encouraging Organizational Innovation: Implications for Stakeholder Management in College Sports. *Journal of Innovative Higher Education*, 38(4), 281-293.
- Craft, A. 2005. *Creativity in Schools: tensions and dilemmas*. UK: Routledge.
- Daft, R.L. 1978. A dual-core model of organizational innovation. *Academy of Management Journal*, 21(2), 193-210.
- Damanpour, F. 1991. Organizational innovation: A meta-analysis of effects of determinants and moderators. *Academy of Management Journal*, 34(3), 555-590.
- Damanpour, F. and Evan, W. M. 1984. Organizational innovation and performance: The problem of organizational lag. *Administrative Science Quarterly*, (29), 392-409.
- De Pablos, J. Colas, P. and González, T. 2010. Enabling factors of ICT innovation in schools. A comparative analysis between different regional educational policies. *Journal of Education*, (352), 23-51.
- Duivenboden, H.V. and Thaens, M. 2008. ICT-driven innovation and the culture of public administration: A contradiction in terms. *Journal of Information Policy*, (13), 213-232.
- Fierro, E., Mercado, P. and Cernas, D.A. 2013. The effect of knowledge-centered culture and social interaction on organizational innovation: the mediating effect of Knowledge management. *Esic Market Economics and Business Journal*, 44(2), 67-86.
- Fornell, C. and Larcker, D.F. 1981. Evaluating Structural Equation Models with it Unobservable Variables and Measurement Error. *Journal of Marketing Research*, (18), 39-59.
- Gomez, M. R., Martinez, A. and Demuner, M.R. 2013. Technology Information and Communication as tools in the teaching of Accounting and Administration. *Revista Iberoamericana for Educational Development*, (10): 1-21.
- Grant, R. M. 1991. The resource-based theory of competitive advantage: Implications for strategy formulation. *California Management Review*, 33(3), 114-135.
- Greiner, L. 1967. Antecedents of planned organizational change. *Journal of Applied Behavioural Science*, 3(1), 51-85.
- Hair, J., Anderson, R. Tatham, R. and Black, W. 2008. *Multivariate analysis*. Madrid: PrenticeHall.
- Hamel, G. (1996). Strategy as revolution. *Harvard Business Review*, 74(4), 69-82.
- Haner, U.E. 2002. Innovation quality -A conceptual framework. *International Journal of Production Economics*, (80), 31-37.
- Hansen, M.T. and Birkinshaw, J. 2007. The innovation value chain. *Harvard Business Review*, 85(6), 21-130.
- Hayduck, L.A. 1987. *Structural Equation Modeling with Lisrel: Essentials and Advance*. London: University Press.
- Hoch, J.E. 2013. Shared Leadership and Innovation: The role of vertical Leadership and Employee Integrity. *Journal of Business and Psychology*, (28) 159-174.
- Huang, H. Che, V.J., Hashem, J., Farihah, K. and Son, R. 2013. The impact of Firm Age on the Relationship among Organizational Innovation, Learning, and Performance: A Moderation Analysis in Asian Ford Manufacturing Companies. *Interdisciplinary Journal of Contemporary Research Business*, 5(4), 166-174.
- Jazkyte, K. 2012. Exploring potencial for Information Techology innovation in Nonprofit Organizations. *Journal of Technology in Human Services*, 30(2), 118-127.
- Jbilou, J., Landry, R., Amara, N. and Adlouni, S. 2009. Combining Communication Technology Utilization and Organizational Innovation: Evidence from Canadian Healthcare Decision Makers. *Journal of Medical Systems*, 33 (4)275-286.
- Jimenez, A.I, Martínez, M.P. and Gonzalez, O. 2008. Implications of proactive market orientation hacia cooperación and the use of ICT in innovation processes productois and services. *Universia Business Review*, (4), 54-67.
- Johannessen, J.A., Olsen, B. and Lumpkin, G.T. 2001. Innovation as newness: What is new, how new, and new to whom? *European Journal of Innovation Management*, 4(1), 20-31.
- Khan, A. M. and Manopichetwattana, V. 1989. Innovative and non-innovative small firms: Types and characteristics. *Management Science*, 35(5), 597-606.
- Kim, C. and Mauborgne, R. 1997. *Value innovation: the strategic log of high growth*. USA: Harvard Business Review.
- Kleinschmidt, E.J. and Cooper, R.G. 1995. The relative importance of new product success determinants-perception verusreality. *Journal of R&D Management*, 25(3), 281-298.
- Law, N., Chow, A. and Yuen, A. 2005. Methodological Approaches to Comparing Pedagogical Innovations Using Technology. *Education and Information Technologies*, 10(1), 7-20.
- Law, N., Yuen, A. and Fox, R. 2011. *Educational Innovations Beyond Technology: nurturing leadership and establishing learning organizations*. New York: Springer.
- Lawrence, P. 1954. How to deal with resistance to change. *Harvard Business Review*, 32(3), 49-57.
- Lester, D.H. 1988. Critical Success factors for new product development. *Journal of Research Technology Management*, 4(1), 36-43.
- Levy, A. and Merry, U. 1986. *Organizational Transformation: Approaches, Strategies, Theories*. New York: Praeger.
- Lévy, J. and Mangin, J.P. 2000. *AMOS modeling and structured programming*. Madrid: Higher Institute of Banking Technique and Practice.

- Lévy, J. and Varela, J. 2006. *Modelación con estructuras de covarianzas en ciencias sociales*. España: Gesbiblo, S.L.
- Linton, J.D. 2002. The potential role of management in undergraduate technical education. *Technology in Society*, 24(3), 361-173.
- Loveless, A. 2008. Creative learning and new technology? A provocation paper, in: Sefton-Green, J., ed. *Creative Learning*. London: Creative Partnerships.
- Maldonado, M. L. 2007. Technologies of Information and Communication a strategic resource for higher education. *Magazine Management Vision*, (2), 257-268.
- Markides, C. and Anderson, J. 2006. Creativity is not enough: ICT-enabled strategic innovation. *European Journal of Innovation Management*, 9 (2), 129-148.
- Markkides, C. 1997. Strategic innovation. *Sloan Management Review*, (38), 9-23.
- Milhim, H. and Schiffauerova, A. 2013. Towards Formalizing and Formulation the Successful Organizational Innovation. *Journal of Integrated Design and Process Science*, 17 (2), 5-21.
- Moheno, G., Valles, R. and Fields, P. 2009. The use of ICT in business innovation: a theoretical review. *Milestones Administrative Economic Sciences*, 15 (4), 41-46.
- Nachmias, R., Mioduser, D., Cohen, A., Tubin, D. and Forkosh-Baruch, A. 2004. Factors Involved in the Implementation of Pedagogical Innovations Using Technology. *Journal Education and Information Technologies*, 9(3), 291-308.
- Navarro, M., Aranguren, M.J. and Magro, E. 2012. Smart specialization strategies: a territorial strategy for regions. *Journal of Management*, 12, 27-49.
- OECD 2010. *Innovation Strategy: getting a head start on tomorrow* (Paris, OECD Publishing). Creative Partnerships.
- Ontiveros, E. 2008. Innovation, ICT and organizational flexibility. The strategic role of education. *Telos magazine* (16), 1-5.
- Penrose, E.T. 1959. *The Theory of the Growth of the Firm*, Oxford: Oxford University Press.
- Pinchot, J. C. and Macedo, I. M. 2006. The benefits and barriers associated with the use of the internet within the non-profit sector. *Journal of Nonprofit and Public Sector Marketing*, 16(1), 171-193.
- Porter, M. E. 1996. What is strategy? *Harvard Business Review*, November-December, 61-78.
- Prasad, V.K., Ramamurthy, K. and Naidu, G. 2001. The Influence of Internet-Marketing Integration on Marketing Competencies and Export Performance. *Journal of International Marketing*, 9(4), 82-110.
- Robbins, S. P. 1996. *Organizational Behavior: Concepts, Controversies and Applications*, Englewood Cliffs, NJ: Prentice Hall.
- Rothwell, R. 1992. Successful industrial innovations: critical success factors for the 1990's. *Journal of R&D Management*, 22 (3), 221-239.
- Ruiz, M. and Mandado, E. 1989. *Technological innovation and management*. Spain: Marcombo.
- Salinas, J. 2004. Teaching innovation and use of ICT in higher education. *Magazine University and the Knowledge Society* (1): 1-6.
- Tang, J.K. 1998. An inventory organizational innovativeness. *Technovation*, 19 (1), 41-51.
- Utterback, J.M. 1994. *Mastering the Dynamics of Innovation*. USA: Harvard Business School Press.
- Vazquez, R.; Santos, M.L. and Álvarez, L.I. 2001. Market Orientation, Innovation and Competitive Strategies in Industrial Firms. *Journal of Strategic Marketing*, 9(1), 69-90.
- Vijande, M. L. and Gonzalez, L.I. 2008. Effect of Total Quality Management in the transformation in technology management innovation. *Journal of Economics and Management*, (37), 33-66.
- Wernerfelt, B. 1995. A Resource-based View of the Firm: Ten years after. *Strategic Management Journal*, (16), 171-174.
- Wu, S. and Lin, Ch. 2011. The influence of innovation strategy and organizational innovation on innovation quality and performance. *International Journal of Organizational Innovation*, 3(4), 45-81.
- Zahra, S. A., De Belardino, S. and Boxx, W. R. 1988. Organizational innovation: Its Correlates and It implications for Financial Performance. *International Journal of Management*, 5, 133-142.
- Zahra, S.A. and Bogner, W.C. 2000. Technology strategy and software new venture's performance: Exploring the moderation effect of the competitive environment. *Journal of Business Venturing*, 15(2), 123-173.
