



ISSN: 0975-833X

## RESEARCH ARTICLE

# POWER SECTION CONFIGURATION AFFECTS OPTIMUM POWER OUTPUTS ON MUD MOTOR DRILLING

<sup>\*,1,2</sup>Atma Yudha Prawira, <sup>1</sup>Budha Maryanti and <sup>3</sup>Etiko Puspo Rini

<sup>1</sup>School of Mechanical Engineering, Balikpapan University, Indonesia

<sup>2</sup>School of Industrial Engineering, MercuBuana University, Indonesia

<sup>3</sup>School of Electromechanical, Polytechnic Institute of Nuclear Technology, Indonesia

### ARTICLE INFO

#### Article History:

Received 27<sup>th</sup> October, 2016

Received in revised form

18<sup>th</sup> November, 2016

Accepted 05<sup>th</sup> December, 2016

Published online 31<sup>st</sup> January, 2017

#### Key words:

Mud Motor,  
Power Section,  
Number of Lobes,  
Optimum Power Produced.

### ABSTRACT

Mudmotors are of multi-lobe positive displacement operating on the “Moineau” principal. A drilling fluid commonly referred to as the “mud” is supplied under pressure from a surface source into the tubing during drilling to wellbore. The drilling fluid operates the mud motor (when used) and discharges at the drill bit bottom. The drilling fluid then returns to the surface via the annular space (annulus) between the drill string and the wellbore wall or inside. Fluid returning to the surface carries the rock bits (cuttings) produced by the drill bit as it disintegrates the rock to drill the wellbore. Generally, there are 2 main section on mud motor which are bearing section and power section. The power section generally includes a housing which houses a motor stator within which a motor rotor is rotationally mounted. The power section converts hydraulic energy into rotational energy by reverse application of the Moineau pump principle. The stator has a plurality of helical lobes which define a corresponding number of helical cavities. The rotor has a plurality of lobes which number one fewer than the stator lobes and which define a corresponding plurality of helical cavities. Generally, the greater the number of lobes on the rotor and stator, the greater the torque generated by the motor. Fewer lobes will generate less torque but will permit the rotor to rotate at a higher speed. Based on torque and rotate speed, determine the optimum power can be produced by power section configurations.

Copyright©2017, Atma Yudha Prawira et al. This is an open access article distributed under the Creative Commons Attribution License, which permits unrestricted use, distribution, and reproduction in any medium, provided the original work is properly cited.

**Citation:** Atma Yudha Prawira, Budha Maryanti and Etiko Puspo Rini, 2017. “Power section configuration affects optimum power outputs on mud motor drilling”, *International Journal of Current Research*, 9, (01), 44673-44677.

## INTRODUCTION

The present invention relates to oil and gas well drilling and more particularly, to an improved mud motor for drilling oil and gas wells and for drilling through obstructions, plugs and the like, in oil and gas wells wherein a high torque, low speed (i.e. low r.p.m.) motor is operated with a reciprocating valve and piston arrangement that uses differential fluid pressure for power and a transmission that isolates impact generated by the reciprocating valve and piston from the drill bit. In desirably low impact situations, there is a need for a drill motor that operates with well drilling fluid or drilling mud. Such “mud motors” have been commercially available for a number of years. All motors referred to as “mud motors” are of multi-lobe positive displacement operating on the “Moineau” principal. One of the limitations of these “mud motors” is their inability to operate in temperatures above about 250° Fahrenheit. Another limitation of such “mud motors” is that they cannot

operate for any length of time on nitrogen or nitrified foam. They typically include a rotating member that is powered with the drilling mud as it flows through an elongated tool body. Suppliers of such “mud motors” include Drilllex, Norton Christiansan, and Baker (Hipp, 2000). To recover oil and gas from subsurface formations, wellbores (also referred to as boreholes) are drilled by rotating a drill bit attached at an end of a drill string. The drill string includes a drill pipe or a coiled tubing (referred herein as the “tubing”) that has a drill bit at its downhole end and a bottomhole assembly (BHA) above the drill bit. The well-bore is drilled by rotating the drill bit by rotating the tubing and/or by a mud motor disposed in the BHA. A drilling fluid commonly referred to as the “mud” is supplied under pressure from a surface source into the tubing during drilling to wellbore. The drilling fluid operates the mud motor (when used) and discharges at the drill bit bottom. The drilling fluid then returns to the surface via the annular space (annulus) between the drill string and the wellbore wall or inside. Fluid returning to the surface carries the rock bits (cuttings) produced by the drill bit as it disintegrates the rock to drill the wellbore (Weirich et al., 2001). Down-hole motors assemblies are well known in the drilling arts. Mud motors are

\*Corresponding author: <sup>1,2</sup>Atma Yudha Prawira,

<sup>1</sup>School of Mechanical Engineering, Balikpapan University, Indonesia

<sup>2</sup>School of Industrial Engineering, MercuBuana University, Indonesia

one well known type of down-hole motors. Mud motors are used to supplement drilling operation by turning fluid power into mechanical torque to a drill bit. The mud is used to cool and lubricate the drill bit, to carry away drilling debris and to provide a mud cake on the walls of the annulus to prevent the hole from sloughing in upon itself or from caving in all together. Mud motors operate under very high pressure and high torque operations and are known to fail in certain, predictable ways. The failure of mud motor is very expensive, as the whole drill string must be pulled out of the bore hole in order to bring the mud motor to the surface where it can be repaired and replaced. This is very time occur with prior art mud motors include; seal failure resulting in drilling mud motor in the universal joint in the transmission section; pressuring up, often called hydraulically locking, due to either fluid or gas being trapped within the confines of the tool itself, and broken bearing mandrels and resulting mud invasion into the bearings (Blair *et al.*, 2004).

### Literature Review

A wellbore is formed in the earth with an elongated, non – rotating tubular drillstem which may consist of a well casing or liner and including an expendable sub and reamer bit part connected to the lower distal end of the drill stem. A retrievable drilling fluid operated motor and drive member assembly are disposed in the drillstem. The motor and drive member include pressure responsive mechanism for engagement with and disengagement from the reamer bitpart to rotatable drive the reamer bit part and a central bit part connected to the drive member without rotating the casing type drillstem. The motor, drive member and central bit part may be retracted from the drillstem upon completion of drilling operations without retrieving the expendable reamer bit part (Winfree, 1995). A drill string typically comprises a tubular which is terminated at a lower end by a drill bit, and terminated at an upper end at the surface of the earth by a “drilling rig” Which comprises draw works and other apparatus used to control the drill string in advancing the borehole. The drilling rig also comprises pumps that circulate drilling fluid or drilling “mud” downward through the tubular drill string. The drilling mud exits through opening in the drill bit, and returns to the surface of the earth via the annulus defined by the wall of the borehole and the outer surface of the drill string. A mud motor is often disposed above the drill bit. Mud flowing through a rotor-stator element of the mud motor imparts torque to the bit thereby rotating the bit and advancing the borehole. The circulating drilling mud performs other functions that are known in the art. These functions including providing a means for removing drill bit cutting from the borehole, controlling pressure Within the borehole, and cooling the drill bit (Konschuh *et al.*, 2011).

A down-hole drilling motor is provided with a bearing unit which supports the output shaft in such an inclined position relative to the motor housing, that the central axis of the output shaft intersects the longitudinal axis of the motor housing at a point of intersection located below the lower end of the housing. Directional drilling of a borehole is carried out by actuating a drill bit by means of the down-hole drilling motor, and simultaneously therewith rotating the drill string and consequently also the motor housing-over periods that are preceded and succeeded by selected periods over which the drill string is not rotated (Kamp, 1985). To obtain hydrocarbons such as oil and gas, boreholes or wellbores are drilled by

rotating a drill bit attached to the bottom of a drilling assembly (also referred to herein as a “Bottom Hole Assembly” or (“BHA”). The drilling assembly is attached to the bottom of a tubing, which is usually either a jointed rigid pipe or a relatively flexible spoolable tubing commonly referred to in the art as “coiled tubing.” The string comprising the tubing and the drilling assembly is usually referred to as the “drill string.” When jointed pipe is utilized as the tubing, the drill bit is rotated by rotating the jointed pipe from the surface and/or by a mud motor contained in the drilling assembly. In the case of a coiled tubing, the drill bit is rotated by the mud motor. During drilling, a drilling fluid (also referred to as the “mud”) is supplied under pressure into the tubing. The drilling fluid passes through the drilling assembly and then discharges at the drill bit bottom. The drilling fluid provides lubrication to the drill bit and carries to the surface rock pieces disintegrated by the drill bit in drilling the wellbore. The mud motor is rotated by the drilling fluid passing through the drilling assembly. A drive shaft connected to the motor and the drill bit rotates the drill bit (Krueger *et al.*, 2002).

It has been recognized that when a down hole motor is rotating the bit on bottom while weight (WOB) is being applied thereto, a reactive torque in the counterclockwise direction is applied to the housing of the motor, which includes the bent housing. The level of such counter torque is directly proportional to the weight-on-bit, and has its maximum level at motor stall. Such reactive torque, and the presence of a bend point in the bent housing, causes lateral forces to be applied to the bit which tend to change the direction of the borehole. However, to control the direction, there must be a way to orient the bend point about the axis of the borehole. As noted above, this is accomplished when using a conventional drill pipe string by simply turning it at the surface. However, coiled tubing cannot be manipulated in this manner. The present invention provides a means and method of orienting the bent housing and its bend point downhole, which enables a directional drilling tool string to be run on coiled tubing (Eddison *et al.*, 1994). When drilling or coring holes in subsurface formations, it is often desirable to be able to vary and control the direction of drilling, for example to direct the borehole towards a desirable target or to control the direction horizontally within the payzone once the target has been reached. It may also be desirable to correct for deviations from the desired direction when drilling a straight hole, or to control the direction of the hole to avoid obstacles (Russell *et al.*, 1993). The two-basic means of drilling a borehole are rotary drilling, in which the drill bit is connected to a drill string which is rotatable driven from the surface, and systems where the drill bit is rotated by a downhole motor, either a turbine or a positive displacement motor. Hitherto, fully controllable directional drilling has normally required the use of a downhole motor, and there are a number of well-known methods for controlling the drilling direction using such a system (Barr *et al.*, 1996). When drilling oil and gas wells for the exploration and production of hydrocarbons, it is very often necessary to deviate the well-off vertical and in a particular direction. Such deviation may be required, for example, when drilling from land to explore formations beneath the sea or below a lake, or in the case of oil and gas production offshore, when drilling 20 or 30 wells from the same platform, each going in a different direction to gain the widest coverage of the hydrocarbon bearing structure. The latter can result in wells being as much as 3 to 4 miles apart at the point where they pass through the production zone (Noble, 1992).

Referring initially to FIG. 1, a borehole 10 is shown extending downward, substantially vertically, from a surface site 11 where a drilling rig (not shown) is located. At some depth below the surface, depending on geology and other factors, the borehole 10 is shown being curved through a section 14 that eventually will bring its outer end to the horizontal. The radius of curvature R of the section 14 is relatively short, and through use of the present invention can be in the order of about 60 feet for an assembly that is used to drill a borehole having a diameter of 61/8". The curved section 14 is drilled with an articulated drilling motor assembly 15 that is constructed in accordance with the present invention. The motor assembly 15 is run on a drill string 16 that typically includes a length of heavy drill collars 17 suspended below a length of drill pipe 18. A lower section of drill pipe 18' is used in the curved section 14 of the borehole 10, since the drill collars usually are too stiff to negotiate the curve and still function to apply weight. A drill bit 20 on the lower end of the motor assembly 15 can be either a rolling cone or a diamond device. The power section 21 of the motor assembly 15 preferably is the well-known Moineau-type design where a helical rotor rotates in a lobed stator in response to drilling mud being pumped through it under pressure. The lower end of the rotor is coupled by a universal-joint shown schematically at 24 to an intermediate drive shaft 73 whose lower end is coupled by another universal joint 25 to the upper end of a hollow mandrel 27. The mandrel 27 is journaled for rotation in a bearing assembly 28, and the drill bit 20 is attached to a bit box 30 on the lower end of the mandrel 27 (Eddison, 1996).

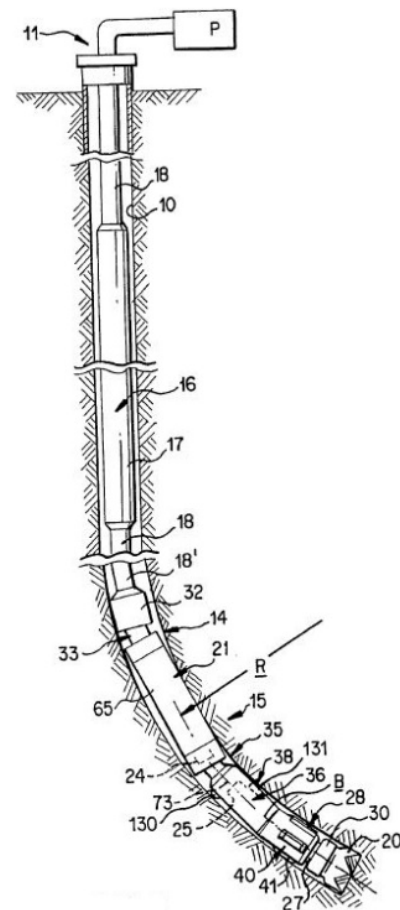

Fig. 1. Drilling Motor Assembly

A drilling motor includes a non-elastomeric stator and rotor which are dimensioned for negative or Zero interference. The amount of negative interference between the rotor and the stator is determined by the largest solid particle expected to pass through the motor. The negative interference or gap between the rotor and the stator is preferably at least two times the greatest particle size. Stators are made by machining or casting stainless steel and are fabricated in sections having lengths of 20 to 40 centimeters. The sections are indexed so that each section may be properly aligned with another. The sections are aligned and welded together to form a motor stator of conventional length. Prior art FIGS. 2 show details of the power section 18 of the downhole motor. The power section 18 generally includes a housing 22 which houses a motor stator 24 within which a motor rotor 26 is rotationally mounted. The power section 18 converts hydraulic energy into rotational energy by reverse application of the Moineau pump principle. The stator 24 has a plurality of helical lobes, 24a – 24e, which define a corresponding number of helical cavities, 24a' – 24e'. The rotor 26 has a plurality of lobes, 26a – 26d, which number one fewer than the stator lobes and which define a corresponding plurality of helical cavities 26a' – 26d'. Generally, the greater the number of lobes on the rotor and stator, the greater the torque generated by the motor. Fewer lobes will generate less torque but will permit the rotor to rotate at a higher speed (Pafitis *et al.*, 2001).

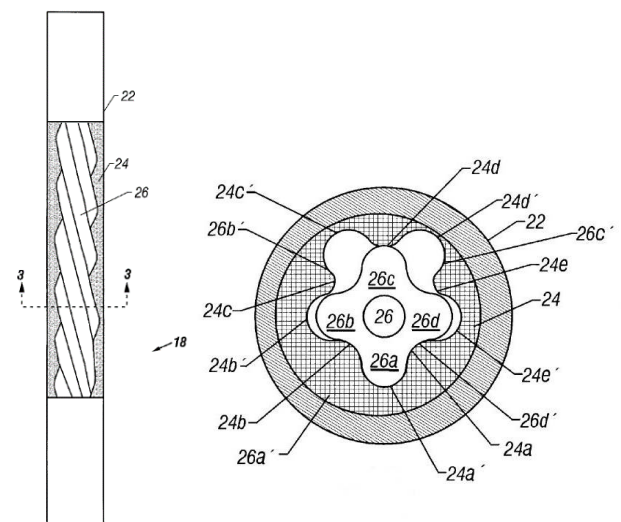

Fig.2. Stator and Rotor with 4:5 lobes configuration

According to Han & Wang (2014), measuring method for motor torque is calculated by:

$$T = \frac{P}{\omega}$$

Where:

T = Torque (Nm)

P = Power (Watt)

$\omega$  = Angular Velocity (Rad/s)

### Research Methodology

This present study analyzes the power section (stator and rotor) configuration affects torque, power and angular speed output on mud drilling motor. There are 4 kinds of the power section configuration in this paper, which are: (a) 1:2 lobes configuration. (b) 2:3 lobes configuration. (c) 5:6 lobes configuration. (d) 7:8 lobes configuration. Each configuration will produce different torque and angular velocity. First collect the field data; torque and angular velocity when running mud motor on each power section configuration. Then determine

the power of the motor. Finally, compare and analyze to decided which configuration can get the optimum power.

## RESULTS AND DISCUSSION

### Torque

Each power section configuration will produce different number of torque. Torque data are shown in Table 1.

**Table 1. Torque data for each power section configuration**

Power Section	Torque (Nm)
1:2 lobes Configuration	3389.54
2:3 lobes Configuration	9290.72
5:6 lobes Configuration	14913.99
7:8 lobes Configuration	18303.54

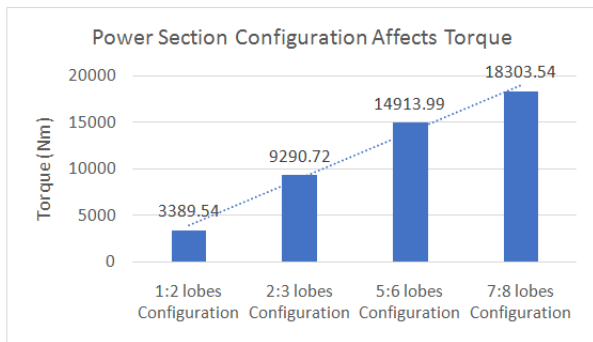

**Fig. 3. Torque are produced by each power section configuration**

From Table 1 and Figure 3, we can conclude that number of lobes in power section configuration is directly proportional with torque produced. The greater number lobes, the greater torqued produced.

### Angular Velocity

Each power section configuration will produce different number of angular velocity. Angular velocity data are shown in Table 2.

**Table 2. Angular velocity data for each power section configuration**

Power Section	Angular Velocity(rad/s)
1:2 lobes Configuration	34.68
2:3 lobes Configuration	20.57
5:6 lobes Configuration	14.13
7:8 lobes Configuration	11.47

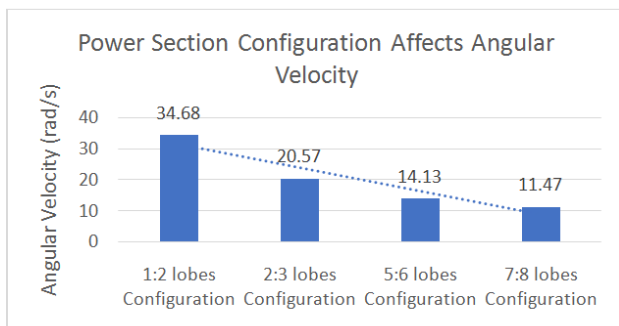

**Fig. 4. Angular Velocity are produced by each power section configuration**

From Table 2 and Figure 4, we can conclude that number of lobes in power section configuration is inversely proportional with angular velocity produced. The greater number lobes, the smaller angular velocity produced.

### Mud Motor Power

From torque and angular velocity data, calculate the mud motor power.

**Table 3. Mud Motor Power**

Power Section	Power (Watt)	Power (HP)
1:2 lobes Configuration	117,549.25	157.63
2:3 lobes Configuration	191,110.11	256.28
5:6 lobes Configuration	210,734.68	282.60
7:8 lobes Configuration	209,941.60	281.54

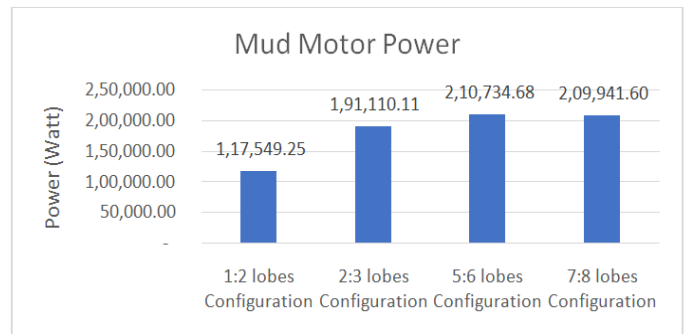

**Fig. 5. Mud Motor Power are produced by each power section configuration**

From Table 3 and Figure 5, we can conclude that optimum power is produced by power section with 5:6 lobes configuration. The power is 210,734.68 watts or 282.60 HP.

### Conclusion

This paper has presented an empirical investigation about the power section configuration affects the number of torque, angular velocity and power produced on mud motor drilling. Especially the number of lobes in power section will influence the number of torque, angular velocity and power produced. So we can conclude that: (a) Number of lobes in power section configuration is directly proportional with torque produced. The greater number lobes, the greater torqued produced. (b) Number of lobes in power section configuration is inversely proportional with angular velocity produced. The greater number lobes, the smaller angular velocity produced. (c) The optimum power is produced by power section with 5:6 lobes configuration. The power is 210,734.68 watts or 282.60 HP.

### REFERENCES

Barr, J. D., Thorp, R. E., & Russell, R. A. 1996. U.S. Patent No. 5,520,255. Washington, DC: U.S. Patent and Trademark Office.  
 Blair, P. E., Ficken, J. L., & Richards, D. J. 2004. U.S. Patent No. 6,827,160. Washington, DC: U.S. Patent and Trademark Office.  
 Eddison, A. M. 1996. U.S. Patent No. 5,520,256. Washington, DC: U.S. Patent and Trademark Office.

- Eddison, A., Leising, L. J., & Ingold, C. 1994. U.S. Patent No. 5,311,952. Washington, DC: U.S. Patent and Trademark Office.
- Han, D., Wang L. 2014. Research on the Loading Method of Motors Based on the AC Synchronous Generator, *Applied Mechanics and Materials*, Vol. 602-605, pp 974-978.
- Hipp, J. E. 2000. U.S. Patent No. 6,050,346. Washington, DC: U.S. Patent and Trademark Office.
- Kamp, A. W. 1985. U.S. Patent No. 4,492,276. Washington, DC: U.S. Patent and Trademark Office.
- Konschuh, C. W., Larronde, M. L., Thompson, L. W., & Wisler, M. M. 2011. U.S. Patent No. 8,011,425. Washington, DC: U.S. Patent and Trademark Office.
- Krueger, V., Rehbock, H., Kruspe, T., Witte, J., & Ragnitz, D. 2002. U.S. Patent No. 6,427,783. Washington, DC: U.S. Patent and Trademark Office.
- Noble, J. B. 1992. U.S. Patent No. 5,113,953. Washington, DC: U.S. Patent and Trademark Office.
- Pafitis, D. G., & Koval, V. E. 2001. U.S. Patent No. 6,241,494. Washington, DC: U.S. Patent and Trademark Office.
- Russell, M. K., & Barr, J. D. 1993. U.S. Patent No. 5,265,682. Washington, DC: U.S. Patent and Trademark Office.
- Thorp, R. E. 1996. U.S. Patent No. 5,553,679. Washington, DC: U.S. Patent and Trademark Office.
- Weirich, J. B., Bland, R. G., Smith Jr, W. W., Krueger, V., Harrell, J. W., Nasr, H. N., & Papanyan, V. 2001. U.S. Patent No. 6,176,323. Washington, DC: U.S. Patent and Trademark Office.
- Winfrey, M. B. 1995. U.S. Patent No. 5,472,057. Washington, DC: U.S. Patent and Trademark Office.

\*\*\*\*\*