



RESEARCH ARTICLE

DETERMINATION OF COMPACTION FORCE IN BUNKER SILOS USING A PRESSURE MEASUREMENT METHOD

^{*}¹Fulya TAN, ²Savas DALMIS, I. and ³Figan DALMIS

¹Namık Kemal University, Agriculture Faculty, Biosystem Engineering Dep. Tekirdag, Turkey

²Namık Kemal University, Corlu Engineering Faculty, Department of Mechanical Engineering, Tekirdag, Turkey

³Namık Kemal University, Vocational School of Technical Sciences, Electronic Technology Program Tekirdag, Turkey

ARTICLE INFO

Article History:

Received 17th October, 2016

Received in revised form

25th November, 2016

Accepted 10th December, 2016

Published online 31st January, 2017

Key words:

Silage, Compression, Bunker silo, Pressure, Compaction.

ABSTRACT

Chopped maize have to be compressed in bunker silos for high quality silage. High losses can occur if the compaction is too low. The main objective of this research was to determine the compaction force at the ensiled material in bunker silo. A pressure measurement method was developed. This method is based on the compaction force determination. Mesens 500 series 4-20 mA of the 4 bar capacity pressure sensor was used. Sensor capacity was determined by the tractor tire pressure. In bunker silos were identified measure points to characterize the silage compaction profile. The experiment was organized in a 3 layer thickness (0.5 m, 1 m, 1.5 m) x three lateral positions (left near the wall, right near the wall and centre) x three areas (A, B and C). Sensors were located during filled the each layer in the bunker silos. Results indicate that a higher compaction force was measured by decreasing layer thickness and by increasing compaction time. The highest pressure was measured in C area due to the higher compaction time.

Copyright©2017, Fulya TAN et al. This is an open access article distributed under the Creative Commons Attribution License, which permits unrestricted use, distribution, and reproduction in any medium, provided the original work is properly cited.

Citation: Fulya TAN, Savas DALMIS, I. and Figan DALMIS, 2017. "Determination of compaction force in bunker silos using a pressure measurement method", *International Journal of Current Research*, 9, (01), 45597-45599.

INTRODUCTION

Compaction is a important factor in the quality of silage. There is a significant relationship between compaction and density. A higher density can be achieved by increasing compaction force, compacting vehicle mass, wheel pressure and number of passages. Compaction is influenced by pressure and layer thickness (Roy *et al.*, 2001). The density of silage in bunker silos is increased with heavy compaction equipment. Heavy tractors of 20 t and more are often used in large bunker silos. Silage density is related to compaction equipment mass (Darby and Jofriet, 1993). Ruppel (1993) reported a significant relationship between silage density, packing time, tractor mass and silo area. Muck and Holmes (1999) also found compaction equipment mass and compaction time were important factors. A single wheel tractor rather than a dual-wheel tractor will apply more pressure locally. However, it will require twice the time to cover the same area, so more compacting time will be needed to achieve enough density (Roy *et al.*, 2011). A pressure measurement method was developed. This method is based on the compaction force determination. The tool that used measuring silage compaction was the same tool which

was used at the study of Turner and Raper (2001). They used this tool for determination of soil compaction. The aim of the project was to determine the compaction force at the ensiled material inside silo during the compaction drives.

MATERIALS AND METHODS

Maize (Pioneer 30B74) was harvested at 25 % dry matter and chopped by a forage harvesting machine (CLASS 940). The chopped material into filled with bunker silos. The CAT 955 L type work machine (ground contact area 2, 03 m²) was used to compress the material.

Bunker silo

The size of bunker silo was 7.5 m wide by 27 m long by 2.25 m high. In bunker silos were identified 24 pressure measure points to characterize the compaction profile at silage (D'Amours and Savoie, 2004). Pressure measurement points in bunker silos are shown in Figure 1. The experiment was organized in a 3 layer thickness (0.5 m, 1 m, 1.5 m) x three lateral positions (left near the wall, right near the wall and centre) x three areas (A, B and C).

*Corresponding author: Fulya TAN,

Namık Kemal University, Agriculture Faculty, Biosystem Engineering Dep. Tekirdag, Turkey.

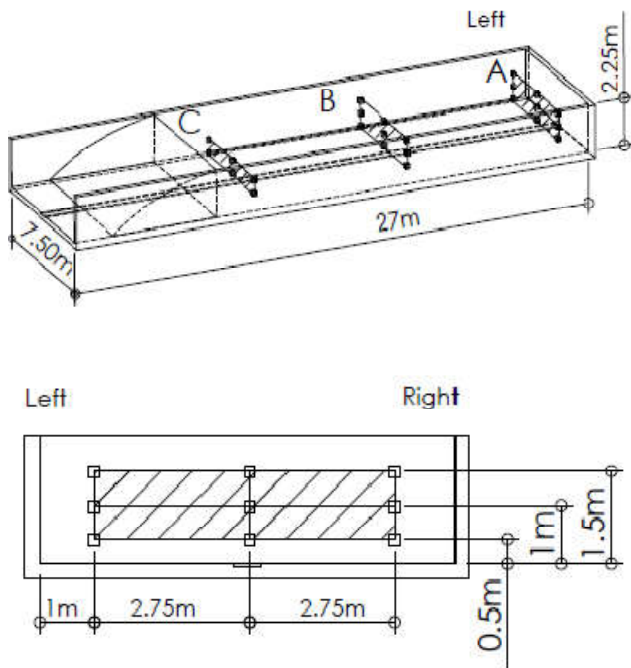

Figure 1. Pressure measurement points and bunker silos

Measurement system

The measurement system has five units mainly (Fig 2). These are;

1. Pressure sensing rubber globe
2. Hydraulic hose connection
3. Pressure sensors
4. Data collection, recording and storage
5. Portable computer

Pressure sensing rubber globes were connected to pressure sensors via the hydraulic hoses. In this hydraulically operated system, water was used for pressure transmission (Turner and Raper, 2001). Mesens 500 series 4-20 mA of the 4 bar capacity pressure sensor was used. Sensor capacity was determined by the tractor tire pressure. The twenty-four pressure sensor units were placed at the specified measurement points. The measurement unit was placed in a central position of the side surface of the silo (Fig.2).

Data acquisition and storage

The data acquisition system is based on a graphical programming language NI LabVIEW software and NI Compact DAQ hardware modules. Data are stored in a MS Excel file on the computer by using user interface created with NI Labview software.

Istatistical analysis: All data were analyzed by SPSS.

RESULTS AND DISCUSSION

Different values at the specified measuring points were measured. This means that compression in bunker silos is variable. The pressure values measured according to the layer thicknesses are shown in Table 1. There is a significant relationship between layer thickness and pressure ($P \leq 0.05$).

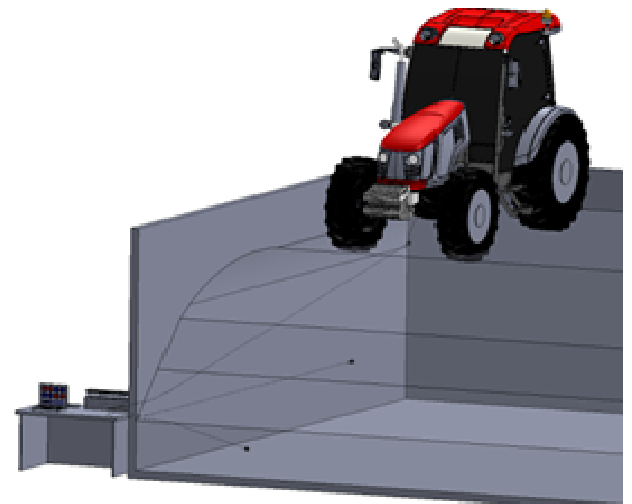
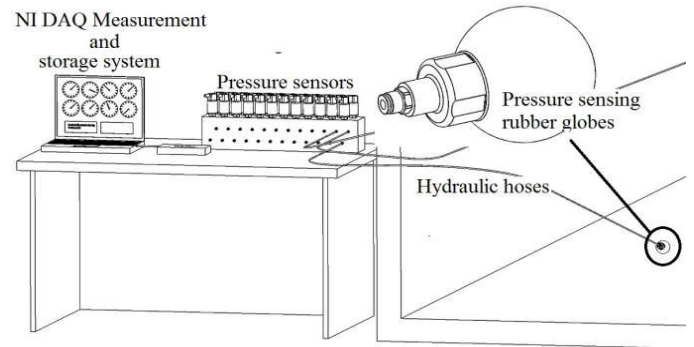

Figure 2. Measurement system

Table 1. Pressure values measured in layer thicknesses

Area	Layer thickness (m)	Pressure (bar)	Min.	Max.	F*
A	0,5	0,270±0,07 a	0,19	0,39	13,05
	1	0,239±0,03 a	0,20	0,31	
	1,5	0,374±0,06 b	0,29	0,50	
Ave.		0,294 a			
B	0,5	0,312±0,12 a	0,12	0,46	4,48
	1	0,302±0,12 a	0,14	0,54	
	1,5	0,438±0,05 b	0,34	0,54	
Ave.		0,350 b			
C	0,5	0,294±0,08 a	0,19	0,50	6,42
	1	0,381±0,09 b	0,26	0,63	
	Ave.		0,337 b		

*Significant at $P \leq 0.05$

Pressure had a significant effect ($P \leq 0.05$) in between the bottom and upper layers. The highest pressure values were measured in the top layer at during the compaction. The effect of the compaction force decreased from the top layer to the bottom layer. This shows that the effect of compaction force is more effective at near distance. Effects of the pressure on areas was significant ($P \leq 0.05$). The lowest compaction force is measured in the A area (0.294 bar). This shows that the compression movement is made less in the area near the rear wall of the bunker silo. The total pressure values measured according to the positions of the sensors (right, center and left) at different layer thicknesses after compression are shown in Figure 3. After compression, the total pressure values remaining in the material were different. The highest pressure value observed at bottom layer (0.5 m), the lowest pressure value at top layer (1.5 m). Similar results were also found by Muck *et al.* (2004). They found that the average density increased from top to bottom of bunker silos due to compaction.

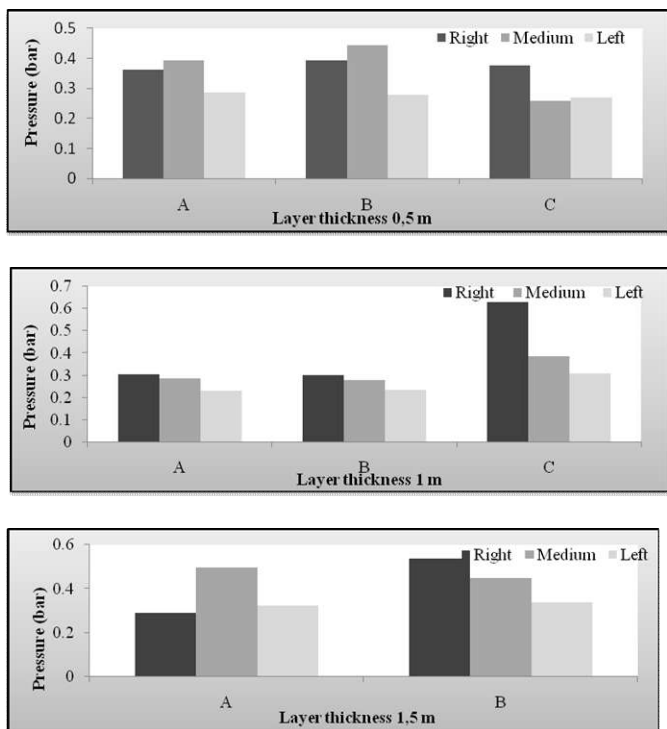

Figure 3. The total pressure values measured according to the positions of the sensors (right, center and left) at different layer thicknesses

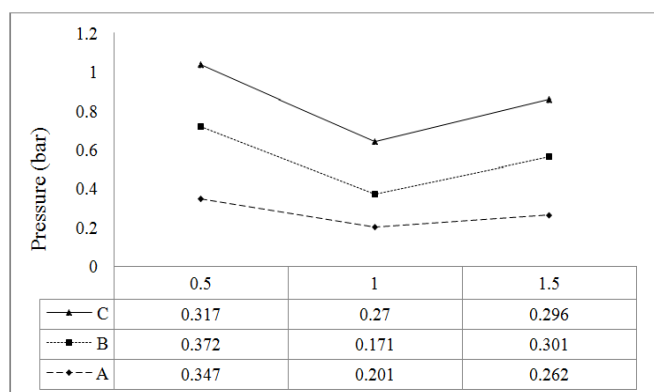

Figure 4. Pressure change in bottom layer at increasing layer thickness

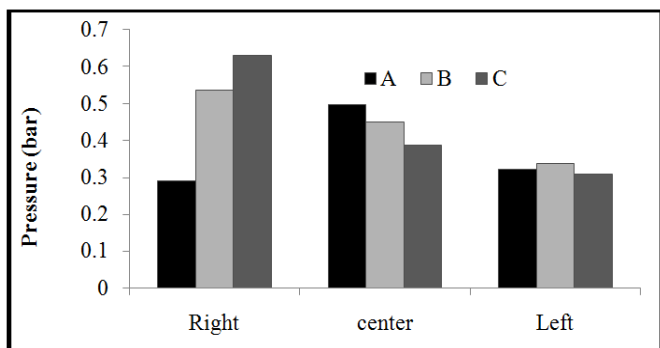

Figure 5. Total pressure measured in right, left and center position

When the layer thickness is low (0.5), the compressive force shows similar values at each position of the silo. The homogeneity also changes, when the amount of material increases. For an effective compaction force, the material must be gradually filled into the silo. The silo filling technique is

very important for good compaction of the silage. The pressure values measured in the pressure sensors positioned at the bottom of the silos as the layer thickness increases is given in Figure 4. The efficiency of compacting is highest when the layer thickness is low (0.5 m). The pressure values measured at 0.5 meter layer thickness was decreased at increasing layer thickness. When the layer thickness is 1.5 meters, the pressure at the bottom is more than 1 meter. This increase is also due to material weight.

Position (right, center, left) of pressure sensors

The total pressure values measured according to the position of the pressure sensors are given in Figure 5. Generally, it is understood that there is more crushing in the right position with the work machine except for A area. On average, the maximum compaction was applied at the middle of the silo. The minimum compaction value is determined in the left position. There are no significant differences between the areas (A,B,C) at the left and center position. The operator who uses the work machine is important. Compaction in the A area is minimized in the right position.

Conclusion

Results showed that decreasing layer thickness has a positive effect on compaction of material. Different pressure values were determined at the pressure measurement points in the bunker silo. Compaction of the material is related to compaction equipment mass, number of passage, operator and compaction time. Similar compression time should be applied in each region of the silo in order to be able to compress the material better and more efficiently.

Acknowledgement

This research was supported by the Namik Kemal University (NKUBAP-422), Turkey.

REFERENCES

D'Amours L, P Savoie, 2004. Density profile of Corn Silage in Bunker Silos. *ASAE* paper Number: 041136.
 Darby D E, and J C Jofriet, 1993. Density of Silage in Horizontal Silos. *Canadian Agric. Engr.*, 35 (4):275-280.
 Muck R E and B J Holmes, 1999. Factors Affecting Bunker Silo Densities. *ASAE Paper No: 991016*. Amer. Soc. Agr. Engr., St. Joseph, MI.
 Muck R E, Savoie P, Holmes B J. 2004. Laboratory Assessment of Bunker Silo Density, Part I:Alfalfa and Grass. *Applied Engineering in Agriculture*, 20(2):157-164.
 Roy M B, Tremblay Y, Pomerleau P. 2001. Compaction and Density of Forage In Bunker Silos. *ASAE Paper No:01-1089*.
 Ruppel K A. 1993. Bunker Silo Management and Its Effects On Haycrop Quality. In *Proceedings From The National Silage Production Conference: 67-82*. *NRAES Publication*, 67, Cooperative Extension, Ithaca, NY.
 Turner R and R L Raper, 2001. Soil Stress Residuals as Indicators of Soil Compaction. *ASAE Paper No. 011063*.