



ISSN: 0975-833X

Available online at <http://www.journalcra.com>

International Journal of Current Research
Vol. 9, Issue, 05, pp.51166-51168, May, 2017

**INTERNATIONAL JOURNAL
OF CURRENT RESEARCH**

RESEARCH ARTICLE

IMPORTANCE OF MANUFACTURING AND ITS SIGNIFICANCE

***Sivasankaran, P.**

Department of Mechanical Engineering, Manakula Vinayagar Institute of Technology, Pondicherry – 605 107

ARTICLE INFO

Article History:

Received 24th February, 2017
Received in revised form
22nd March, 2017
Accepted 04th April, 2017
Published online 31st May, 2017

Key words:

Production volume, Workforce,
Transportation, Labors.

ABSTRACT

Manufacturing is considered to be a global enterprise started during the late 19th century itself to cater the needs of large scale production. After 19th century manufacturing business have changed drastically through the innovations of technology, processes, materials and transportation. The major challenge of manufacturing is to produce more number of products with less material, less energy and fewer labors. In this paper various types of manufacturing environment is addressed with respect to the difference in production volume and amount of workforce required.

Copyright©2017, Sivasankaran. This is an open access article distributed under the Creative Commons Attribution License, which permits unrestricted use, distribution, and reproduction in any medium, provided the original work is properly cited.

Citation: Sivasankaran, P. 2017. "Importance of manufacturing and its significance", *International Journal of Current Research*, 9, (05), 51166-51168.

INTRODUCTION

Manufacturing industry involves in the manufacturing and processing of items and indulges in either creation of new commodities or in value addition. Growth of manufacturing enterprise decides the country's economy by considering all aspects such as manpower, materials, machineries, technology, money etc. Final products obtained from manufacturing can either serve as finished products for sale to consumers or intermediate products used in the production process. Manufacturing industries are the chief wealth producing sectors of an economy. These industries use various technologies and methods widely known as manufacturing process management. Manufacturing industries are broadly categorized into engineering industries, construction industries, electronics industries, chemical industries, energy industries, textile industries, food and beverage industries, metalworking industries, plastic industries, transport and telecommunication industries. Manufacturing industries are important for improving the country's economy as they employ a huge share of the labor force and produce materials required by sectors of strategic importance such as national infrastructure and defense. As a whole manufacturing industry generates more profits by means of revenue also it creates more job opportunities to the individuals. Also it improves the skills of workforce by experiencing the problems in the working

environment. In order to face these challenges the manufacturing industry must have suitable strategy to define the objective also to win in the competitive environment. According to Skinner (2007), "a manufacturing strategy is a set of manufacturing policies designed to maximize performance among trade-offs among success criteria to meet the manufacturing task determined by a corporate strategy". Competitiveness of manufacturing industry based on two possible factors they are as follows structural and infrastructural facilities. There are four structural areas that are comprised of capacity, facilities, technology, and sourcing. The infrastructural areas are workforce, quality, production planning, and organization. The performance of manufacturing enterprise must conform to the quality standards such as reduced cost, high quality, and high reputation in global level.

Literature review

As per the hierarchy of literature manufacturing industries are classified into various types they are as follows:

High Volume Manufacturing

High volume production also known as mass production. Mass production means involves products producing in large quantities. Mass production involves high demand rate of the particular product. Normally, for high volume manufacturing, only small numbers of different products are manufactured by the company. In high volume production the operations are

**Corresponding author:* Sivasankaran, P.

Department of Mechanical Engineering, Manakula Vinayagar Institute of Technology, Pondicherry – 605 107

linked together in a assembly line. It means that after completion of one operation on a product, it moves to the next subsequent operation in the assembly line. Thus the same process is carried out until the final assembly line receives the finished product.

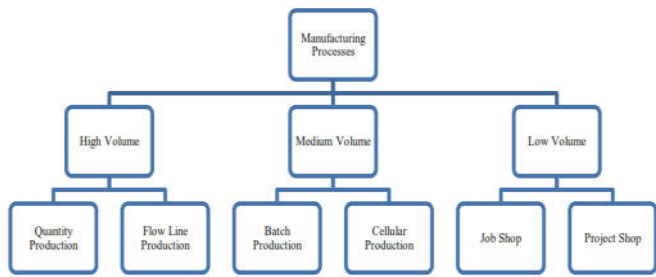

Fig.1. Classification of manufacturing

Quantity production

Quantity production is one type of production which comes under high volume production. Quantity production concentrates on a single product by using single standard equipment. For example components coming out from the die casting which involves repetitive operation. Thus the operation is termed to be a continuous process. Hence in this process the machine will turn the material into final product as per requirements until the desired quantity is achieved.

Flow line production

Flow line production also known as sequential production which carries the job in sequential order without violating the constraints. Flow line production is considered to be high volume, standard production units. Flow line production follows product layout which is usually arranged in long line of workstations connected by conveyors.

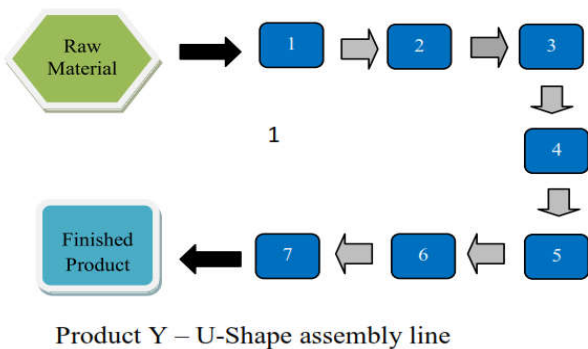
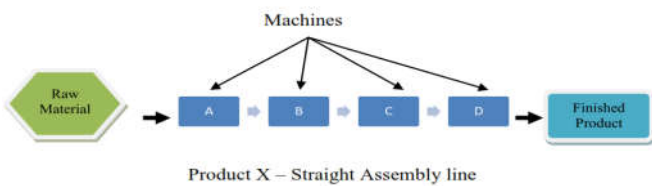

Fig.2. Product layout

Assembly lines

An assembly line is a manufacturing process which has linkage with many workstations by conveyors or a similar material

handling system so that each product goes from one operation directly to the next and so on. An assembly line consists of serial number of workstations that consistently perform certain operations on a work piece for assigned cycle time (maximum or average time available for each work cycle). As a result, each product follows the same kind of operations and identical final product is expected at the end of the assembly line. The complexity involved in producing a product is mainly based on the number of components and assembly levels. As per literature in assembly lines there are many classifications as follows:

1.Single model lines:

Single model lines are designed to carry out same kind type of jobs, so single model lines are considered to be monotonous in nature. This type of assembly line is commonly used in high volume production.

2.Mixed model lines:

Mixed model lines are designed in such a way to handle multiple number of models within the same assembly line by producing products in a mixed sequence. As compared to the traditional systems this type of assembly lines has more benefits such as optimizing lead time, cost and quality.

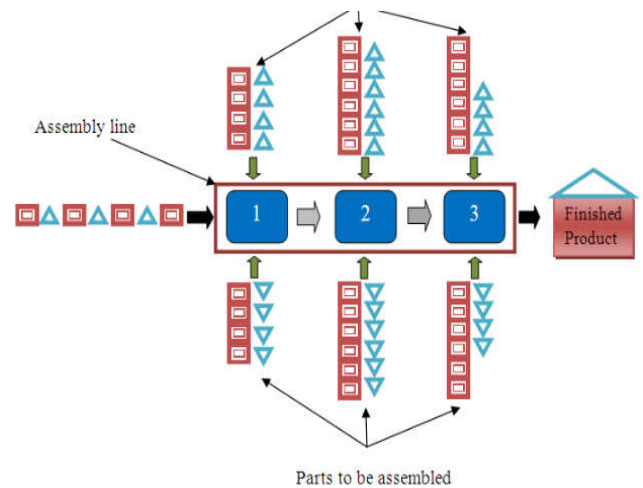

Fig.3. Mixed model lines

Transfer lines

Transfer lines are mainly employed in manufacturing environment to perform the jobs more effectively, precisely and economically. As like mixed model in transfer line variations of products can be produced by using the same type of production line. It creates the opportunity to produce more demand for product varieties. Transfer lines work by passing work pieces sequentially through all workstations at constant speed and controlled speed. These types of lines are designed for mass production of a single product or group of similar products.

Continuous production systems

This process works by producing the material or product continuously to create more demands by maximizing the efficiency and effectiveness. Continuous production involves high volume production by moving the materials continuously

from one stage to another stage. one can use continuous production to estimate how realistically it takes the materials to transfer into final product.

Material handling systems in manufacturing

Material handling system is considered to be the most important component in manufacturing which acts as inter connector for facilities as well as to facilitate the right quantity of raw materials at right place in right time. Material handling systems are responsible for transferring the materials from one place to another place between the work stations. Material handling systems is considered to be the integral functions of all manufacturing systems. Effective material handling system should improve the performance of the manufacturing system by reduced work in process inventory.

Facility layout

In manufacturing systems facility layout has got significant impact in improving the manufacturing productivity in terms of cost and time. The main objective of layout is to minimize the material handling cost, improve flexibility in arranging the available area and controlling the overall production time. Good facility layout helps in improving the production planning and scheduling operations of enterprises.

Medium volume manufacturing

Medium volume manufacturing has two types of manufacturing as follows: 1. Batch production 2. Cellular manufacturing. Each type of production systems depends upon the product varieties.

Batch production

Batch production there are variety of products manufactured as per the requirements but in limited quantity. Once the given batch of products is produced, the manufacturing system is changed over to produce another batch of products. Thus batch production systems are intermittent in nature since the demand is not continuous.

Cellular manufacturing

The main purpose of cellular manufacturing is to group machines into machine cells and parts into part families. Cellular manufacturing arranges the job or work part as per similarity of machines and work part within the cells. Cellular manufacturing system helps to improve the efficiency by simplifying the work by clubbing work parts and machines as per similarity. The main advantages in CM are to regroup the available machineries as per availability.

Flexible manufacturing systems

FMS means integration CNC and automated material handling systems under computer control. Flexibility deals with high quality customized products and focus on fast delivery of products to the markets on reasonable price. FMS is a method of producing goods that is readily adaptable to any changes in the product being manufactured. In FMS there are different types of flexibilities such as machine flexibility, routing flexibility, part flexibility and operation flexibility.

Conclusion

In this paper various classification of manufacturing problems are discussed along with its significance impact with respect to various situations. Thus manufacturing is considered to be broad spectrum with technological advancements also on the same side manufacturing primarily focuses on improvement of productivity by considering the optimal amount materials, technology and labor. As a whole manufacturing is not the single function it is considered to be the integral of many entities.

REFERENCES

- Boks, C., Nilsson, J., Masui, K., Suzuki, K., Rose, C., Lee, B., 1998. An international comparison of product end-of-life scenarios and legislation for consumer electronics. In: Proceedings from the IEEE Symposium on Electronics and Bowen,
- Callahan, J.S., Dunne, R.A., Stanaback, S., 1997. New Jersey county dismantles recycling and emissions problems. *World Wastes* 40 (3), 7–8.
- Christina W.Y.Wong, Kee-hungLai, Kuo-ChungShang, Chin-ShanLu, T.K.P. Leung, 2012. Green operations and the moderating role of environmental management capability of suppliers on manufacturing firm performance, *Int. J. Production Economics*, 140; 283 -294.
- Christmann, P., 2000. Effects of “best practices” of environmental management on cost advantage: the role of complementary assets. *Academy of Management Journal*, 43 (4), 663–680.
- Chun-Jen Chung, Hui-Ming Wee, Green-component life-cycle value on design and reverse manufacturing in semi-closed supply chain, *Int.J.Production Economics*, 113 (2008)528-545
- Cooperation between cooperations and environmental groups: a transaction cost perspective. *Academy of Management Review*, 32 (3), 889–900.
- Corbett, C.J., Klassen, R.D., 2006. Extending the horizons: environmental excellence as key to improving operations. *Manufacturing and Service Operations Management*, 8 (1), 5–22.
- David A. Dornfeld, I. S. Jawahir, Andres F. Clarens, A Review of Engineering Dechant, K., Altman, B., 1994. Environmental leadership: from compliance to competitive advantage. *Academy of Management Executive*, 8 (2),7–20.
- F., Cousins, P.D., Lamming, R.C., Faruk, A.C., 2001. The role of supply management capabilities in green supply. *Production and Operations Management* 10 (2), 174–189.
- Ferguson, M.E., Toktay, L.B., 2006. The effect of competition on recovery strategies. *Production and Operations Management* 15 (3), 351–368.
- Handfield, R.B., Walton, S.V., Seegers, L.K., Melnyk, S.A., 1997. ‘Green’ value chain practices in the furniture industry. *Journal of Operations Management*, 15 (3), 293–315.
- Hunt, C.B., Auster, E.R., 1990. Proactive environmental management: avoiding the toxic trap. *Sloan Management Review*, 31 (2), 7–18.
- Karl R. Haapala, Fu Zhao, Jaime Camelio, John W. Sutherland, Steven J. Skerlos Karthik Ramani, Devarajan Ramanujan, William Z. ernstein, Fu Zhao, John Sutherland, Carol Handwerker, Jun-Ki Choi, Harrison Kim, Deborah Thurston, Integrated Sustainable Life Cycle Design: A Review, *Journal of Mechanical Design*, Vol 132 September 2010 King, A., 2007.