



ISSN: 0975-833X

RESEARCH ARTICLE

DEVELOPMENT OF A PROTOTYPE SENSOR FOR MEASURING GROUND REACTION FORCE ON A WALKING ROBOT

Kiran Divakaran and P.V. Shanmuganathan*

Mechatronics Division, School of Mechanical and Building Science, VIT University, Vellore 632014.

ARTICLE INFO

Article History:

Received 15th August, 2011
Received in revised form
19th September, 2011
Accepted 17th October, 2011
Published online 20th November, 2011

Key words:

Biped, Walking,
Strain Gauge,
Control, DAQ.

ABSTRACT

This article focuses on the design, development and fabrication of the strain measuring sensor and its interface with a data acquisition system which converts the force applied on the rigid frame of the leg to a voltage potential which can be used for further processing. The sensor element used for the experimentation is a transducer class of strain gauge which are open gauges with a constant alloy pattern constructed on a thin polyimide-film backing and is pasted on a GI sheet. The strain gauge is then interfaced with a Wheatstone bridge and is interfaced with a National Instruments SCC-68 interface card and PXI-6259 DAQ system.

Copy Right, IJCR, 2011, Academic Journals. All rights reserved.

INTRODUCTION

Research interest in humanoid robots developed in the 1980's, with the rapid strides of microprocessor technology which paved the way for autonomous robots. It soon became an inevitable direction for future research. Today, over three decades later, there are a wide variety and range of walking machine prototypes starting from the roadside toys to the mighty Honda ASIMO. However the vision of a reliable legged locomotive is yet to be achieved. One may wonder why legged when wheeled locomotion is possible. Legged locomotion enables better flexibility on rough terrain. Legs allow for more instantaneous control than wheels, since we can push off or brake very effectively during the intermittent contact with the ground at each step. Legged machines also can be incorporated as sophisticated tools for prosthetics and collaborative robots which can interact seamlessly in the same environment in which humans work, live and play and to better understand the science of animal and human locomotion itself. Comparing the dynamic walking approach with that of humanoids such as ASIMO, passive-dynamic approach essentially mimics the dynamics of human walking. I.e. human walking can be compared to inverted pendulum motion. The resulting under-actuated limit cycle gaits are quite fragile to perturbations from terrain variation or other interactions with the surroundings. A highly-actuated humanoid robot like the Honda's ASIMO employs a much fuller set of actuators and relies much less on natural, passive dynamics. Although adding more degrees of actuation increases the potential for greater robustness and flexibility in motion, it also increases the complexity of the control necessary. Humanoids such as ASIMO can achieve precise

foot placement, but they are not yet capable on significantly rough terrain. The initial works for using the force feedback from the foot of the robot so as to incorporate piezo materials in the foot for active foot control is compiled in this article.

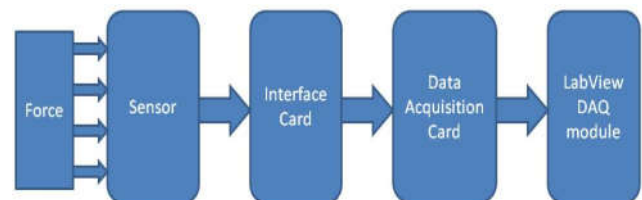

Fig.1: Block Diagram of the Force Measurement System

Sensor Design

The sensor element used for the experimentation is a transducer class of strain gauge which are open gauges with a constant alloy pattern constructed on a thin polyimide-film backing. It is capable of low and repeated creep applications with a very rugged construction which will help protect gauge handling damages. Single active strain-gauge element is mounted in the principle direction of axial or bending strain.

Z

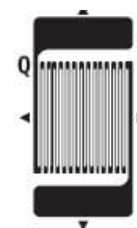

Fig. 2: The sensor element

Sensor mounting

- Ensure the surface is degreased. Isopropyl alcohol, carbon tetrachloride or trichloroethane can be used for this purpose.
- Put few drops of Conditioner to the surface, then rub with 320 grit emery paper, then wipe the surface clean with a clean absorbent cloth.
- Repeat step until the cloth does not show any trace of dirt after wiping the surface.
- Apply a few drops of Neutralizer on the surface, scrub with cotton buds and wipe the surface clean again with a gauze sponge
- Use Flat forceps to remove a strain gauge from its folder, and place it on a clean glass plate. The shiny bright side of the strain gauge should be facing up. The dull matt side of the strain gauge should be kept in contact with the glass plate.
- Apply a length of cellophane tape on the strain gauge, and then lift the cellophane tape, with the gauge stuck to its lower side.
- Position the strain gauge at the intended location on the cleaned surface of the plate, and tack the tape on the surface on one side of the strain gage. Lift one side of tape to expose the underside of the strain gauge
- Apply adhesive to the intersection of the tape and the surface of the plate using thin hollow plastic rod to dip into the bottle and extract a couple of drops of the adhesive.
- Hold the tape so that the strain gauge is just above the surface of the specimen, then wipe down the tape with a gauze sponge, to squeeze out excess adhesive from under the strain gage. Immediately place a thumb on the tape above the gauge and apply pressure. Hold the pressure on the gauge for few minutes.
- Peel the tape back on itself. The tape should come off, and the gauge should remain bonded to the specimen.
- Cover the sensitive part of the strain gauge with drafting tape and apply solder to the strain gauge tabs.
- Remove insulation from the lead wires, and apply solder to the exposed leads. Trim the leads if needed.
- Position the lead wires over the tinned tabs of the strain gage, and apply fresh solder to the joint, so that the lead wires are soldered to the tabs of the strain gage.
- Anchor the lead wires to the surface of the specimen with strong tape.
- Apply rosin solvent to the strain gauge. This should release the drafting tape covering the gauge. Clean the soldered joint of the gauge, and the entire gauge surface with the rosin solvent using a soft paint brush.
- The strain gauge is now ready to make measurements.

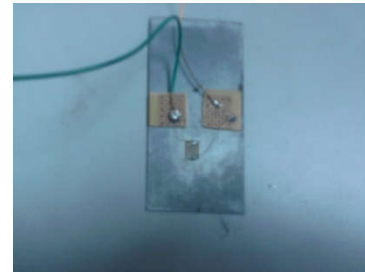

Fig. 3: The strain gauge mounted on a plate

The gauge factor of the strain gauge is 2.07 and its gauge resistance is 120 ohms.

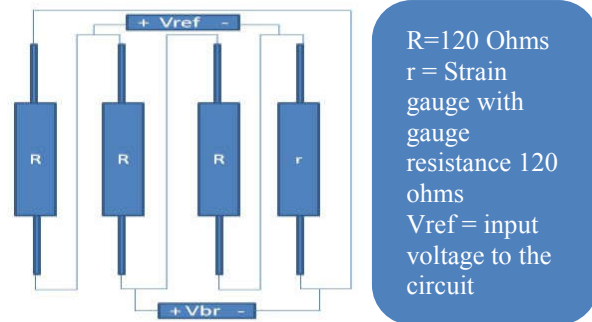

Fig. 4a: Circuit connections

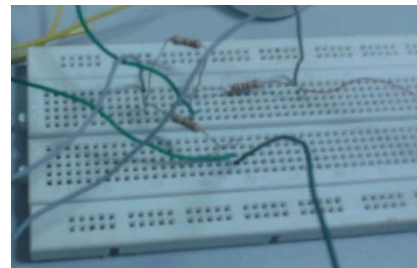

Fig. 4b: Circuit fabrication on a breadboard

The data acquisition system

The DAQ system used is a National Instruments SCC-68 interface card and PXI-6259. In measurement applications, the measurement itself is often only the first step. Processing and analysis are typically required to interpret and better understand the measurements that have been taken. Traditional methods for analyzing data involved writing down measurements and manually entering recorded values into a spreadsheet program, or using an instrument control bus to save data to disk for offline processing and analysis. Inline processing and analysis form a new level of measurement automation that saves time and generates the results more quickly. Because of the rapid adoption of multi-core processors and faster buses such as USB 2.0 and PCI Express, we can take advantage of PC technology to implement signal processing and analysis in real time while data is being acquired. This reduces the amount of time needed to search through data files and to perform offline analysis. As seen in the figure below, the data Acquisition system consists of a Sensor, signal conditioning unit, and the software which runs on a computer.

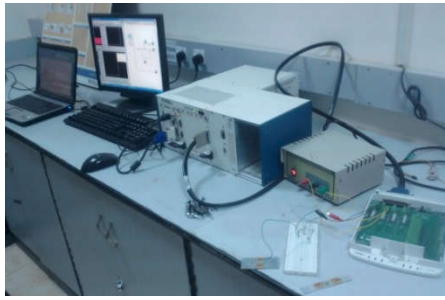

Fig. 5: Data Acquisition System Setup

DAQ Design

The DAQ used is configured to receive 2 channel input in the range of -5V to +5V. The sampling rate is 200Hz of which 100 samples are read for the analysis. The channel details are as shown in the Table 1.

Table 1: Two Channel Input Configuration

Sl. no	Channel	Range	Sampling rate	Samples to read
1	V_{ref}	-5 to +5V	200 Hz	100
2	V_{br}	-5 to +5V	200 Hz	100

The Interface Card

The interface card used is a National instruments interface card SCC-68. It has the option of either providing external supply or can internally power itself from the PXI chassis in the computer. The figure 6 below shows the power distribution block diagram.

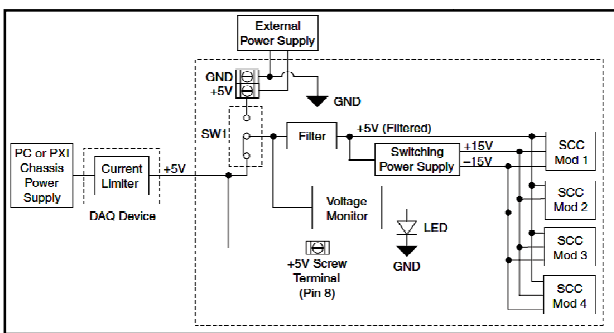

Fig. 6: SCC-68 Interface Card Power Distribution Block Diagram

The V_{br} is connected to ai0 channel and the V_{ref} is connected to the ai1 channel. The yellow wires connect to the V_{ref} and the black wires to the V_{br} . The wires are connected to the sensor element which was prepared previously and are connected to the sensor bridge as shown in the Figure 4.

Data acquisition card

The National Instruments PXI-6259 is a high-speed multifunction data acquisition (DAQ) board optimized for superior accuracy at fast sampling rates. It comes with an 18-bit analog-to-digital converter providing a 4X resolution increase. This High-speed device incorporate advanced

features such as the NI-STC-2 system controller, NI-PGIA-2 programmable amplifier, and NI-MCal calibration technology to increase performance and accuracy. This device has an onboard NI-PGIA-2 amplifier designed for fast settling time at high scanning rates which will ensure 16-bit accuracy even when measuring all channels at maximum speeds.

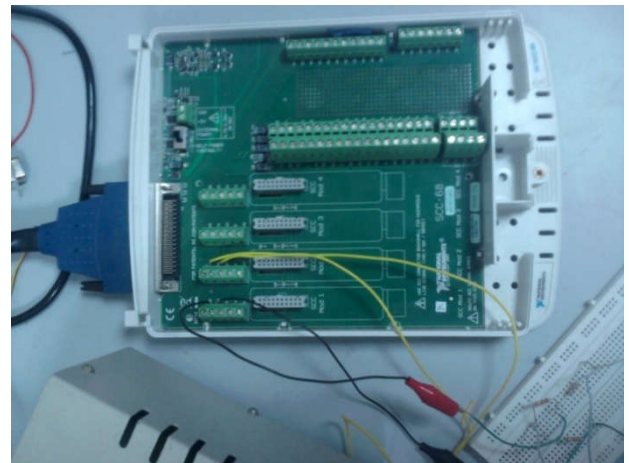

Fig. 7: the sensor bridge connected to the interface card



Fig. 8: The PXI 6259 DAQ card

LabVIEW Virtual Instrumentation:

The data acquisition system is made using the virtual instrumentation technique using LabVIEW. It is a graphical programming environment used to develop sophisticated measurement, test, and control systems using intuitive graphical icons and wires that resemble a flowchart. It offers integration with a wide spectrum of hardware devices and provides a host of built-in libraries for advanced analysis and data visualization using virtual instrumentation.

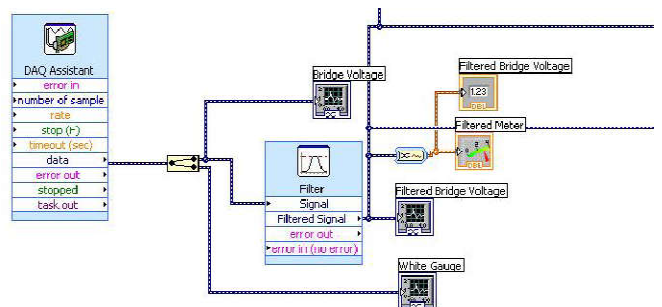

Fig. 9: Screen shots of the various stages in the Virtual instrumentation used

The figures show the screenshots of the virtual instrumentation used also known as the backend of the DAQ. This block diagram has 2 main parts. First is the "DAQ Assistant" which is meant to sample 2 voltage waveforms. These correspond to the bridge voltage and the Reference Voltage Adjust the input range for both the channels to -5V to +5V . The range being sampled should be as close as possible to the range of the signal. The sampling is set to "Continuous", Number of samples to be read to 100 and Sampling Rate to 200 Hz. for both the channels. These values are not the only values which will work, but they have been shown to work. Both the waveforms are to be displayed in their native form. I.e. To split the waveforms, you need to utilize a split waveform object. This object takes the two channels sampled by the DAQ assist and splits them into the two discrete channels (i.e. V_{ref} and V_{br}). The second part is the Filter and the filtered waveform display. The block diagram for this is as shown in figure 10 below.

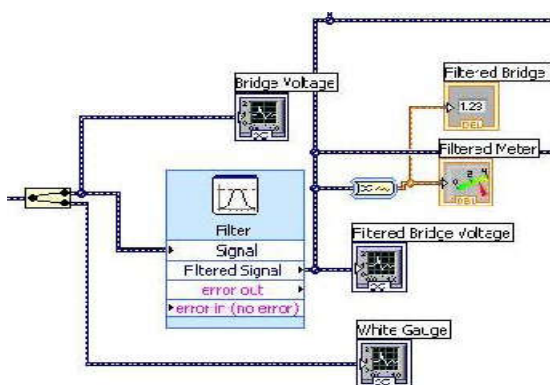

Fig. 10: Signal Processing Block Diagram

The filter is set to be a smoothing rectangular filter with the half width of moving average as 50.

RESULTS AND CONCLUSION

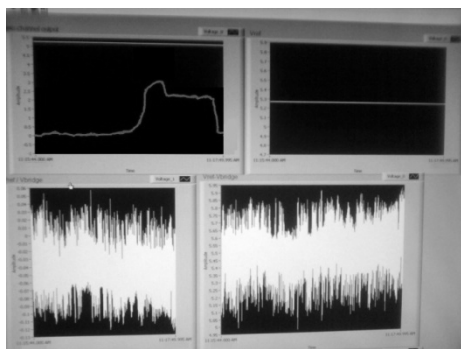

Fig. 11: Screenshot of the front end when a load is applied

The figure 11 above shows the data acquired from the sensor element in graphical form. The sensor element can now be calibrated and similarly fixed to a robot's leg so that the ground reaction force can be determined so as to further determine the kinds of forces an active flexible foot has to exert for enabling it to walk.

REFERENCES

Salisbury, K. 1980. Active stiffness control of a manipulator in Cartesian coordinates. In *Proc. of the 19th IEEE Conference on Decision and Control*, 1980

Hao Xiaoxia, Zhou Runjing. Development of a Bedsores Prevention System Based on LabVIEW. *5th International Conference on Information Technology and Application in Biomedicine*, 2008.

Koichi Nishiwakit, Yoshifumi Murakamit, Satoshi Kagamit. A Six-axis Force Sensor with Parallel Support Mechanism to Measure the Ground Reaction Force of Humanoid Robot. *IEEE International Conference on Robotics & Automation*, MAY 2002.

Pei-Chun Lin. Proprioceptive Sensing for a Legged Robot. *Doctoral Thesis, The University of Michigan*.2005

JUNG-YUP KIM, JUNGHO LEE and JUN-HO OH. Realization of Dynamic Walking for a Human-Riding Biped Robot. *HUBO Laboratory, Human Robot Research Center*.

Tao Liu , Yoshio Inoue, Kyoko Shibata. Wearable force sensor with parallel structure for Measurement of ground-reaction force. *Measurement transactions on Elsevier / Science direct (2007) 644-653*

TORU TAKENAKA. The control system for the Honda humanoid robot. *Wako Research Centre, Honda R&D Co., Ltd, LabVIEW Self Help and Self Tutorial Files*. Discussion Forums on NI Developer Zone

Pereira, F.M.T. and J.A.T.Machado, "Kinematic Analysis and Modelling of Biped Locomotion Systems." *University of Aveiro & University of Porto*, Portugal 1999.

Huang, Q., K. Yokoi, and S. Kajita, "Planning Walking Patterns for Biped Robot." *IEEE Transactions on Robotics and Automation*, pp 280-289 Vol.17, No3, June 2001.

Shanmuganathan, P.V. Dynamics and Stabilization of Under-Actuated Mono-pedal Hopping." Ph. D Thesis, IIT Bombay, 2002.

Sardain, P. and G. Bessonnet, "Forces acting on a Biped Robot. Centre of Pressure, Zero Moment Point". *IEEE Transactions on Systems, Man, Cybernetics*, pp 630-637 ,Vol.34, No.5, Sept 2004.

Kim, J. Y., I. W. Park and J. H. Oh. "Walking Control Algorithm of Biped Humanoid Robot on Uneven and Inclined Floor," *Journal of Intelligent Robot Systems*, pp 457-484, Springer Science, Jan 2007.

Tang, Z.,C. Zhou and Z. Sun, "Humanoid Walking Gait Optimization Using GA-Based Neural Network," *International Conference on Natural Computation (ICNC(2))*, Beijing, China, 2005 pp. 252-261.

Ohtake, S., M. Yamakita, and S. Hyon, "Control of Under-Actuated Biped Running Robot via Synchronous Oscillator," *IEEE SICE Annual Conference*, Aug 2008.

E.A. Yazdi and A. Alasty "Stabilization of biped walking robot using energy shaping method," *ASME Journal of Computational and Nonlinear Dynamics*, Vol 3/ 041013, Oct 2008 ASME.

Chevallereau, C. "Time scaling control of under actuated biped robot," *IEEE Transactionson Robotics and Automation*. Vol 19, No.2, April 2003, pp 362-368.

Sangwan, V., H. Kuebler, and S. K. Agarwal, "Differentially Flat Design of Under-Actuated Planar Robots," *Proceedings of IEEE International Conference on Robotics and Automation*, May 2008, pp 2423-2428.

Sangwan, V. and S. K. Agarwal, "Leg-Like Motion with Under-Actuated Two DOF Linkage Using Differential Flatnes,," *Proc. American Control Conference*, June 2006, Minnesota, USA.