



## RESEARCH ARTICLE

### BLOCKING OF SIGNAL USING SIGNAL JAMMER

**1,\*Saurabh Singh, <sup>2</sup>KrishnaYadav, <sup>3</sup>Rishabh singh, <sup>4</sup>Akash Soni, <sup>5</sup>Harjeet Matharuf  
and <sup>6</sup>Pranay Rao**

<sup>1,2,3,4,5</sup> Department of Electronics and Communication Engineering, Mumbai University, Thakur College of Engineering and Technology

<sup>6</sup>Department of Information Technology, Mumbai University, Thakur College of Engineering and Technology

#### ARTICLE INFO

##### Article History:

Received 19<sup>th</sup> September, 2017  
Received in revised form  
17<sup>th</sup> October, 2017  
Accepted 04<sup>th</sup> November, 2017  
Published online 27<sup>th</sup> December, 2017

##### Key words:

Transistors,  
Capacitors,  
Inductance,  
GSM Antenna.

**Copyright** © 2017, Saurabh Singh et al. This is an open access article distributed under the Creative Commons Attribution License, which permits unrestricted use, distribution, and reproduction in any medium, provided the original work is properly cited.

**Citation:** Saurabh Singh, KrishnaYadav, Rishabh singh, Akash Soni, Harjeet Matharuf and Pranay Rao. 2017. "Blocking of Signal using Signal Jammer", *International Journal of Current Research*, 9, (12), 62344-62347.

#### ABSTRACT

This paper proposes and aims at designing a GSM jammer. GSM jammer is a device that transmit signal on the same frequency at which the GSM system operates. The mobile phones in the area where the jammer is located are disabled. This project is mainly intended to prevent the usage of mobile phones in places inside its coverage without interfering with the communication channels outside its range, thus providing a cheap and reliable method for blocking mobile communication in the required restricted areas only. The circuits that use for GSM jammer are Tuning Circuit, Voltage Controlled Oscillator, RF Amplifier and Antenna form the Jammer circuit. All the circuit output are constructed and observed using the Electronic workbench. The simulation result and practical result were studied and they were found to be approbatory equal. The gain of the project is that we are able to block communication coming into and going out from a GSM phone operating on the 890MHz to 960MHz frequency band.

## INTRODUCTION

A GSM Jammer is a device that transmit signal on the same frequency at which the GSM system operates. The mobile phones in the area where the jammer is located are disabled. Communication jamming devices were first developed and used by military. Tactical commanders use RF communications to exercise control of their forces and an enemy has interest in those communications. This interest arises from the fundamental area of denying the successful transport of the information from the sender to the receiver. Nowadays the mobile jammer devices are becoming civilian products rather than electronic warfare devices and now since with the increasing number of the mobile phone users, the need to disable mobile phones in specific places where the ringing of cell phone could be disruptive and not allowed has increased. These places include worship places, university lecture rooms, libraries, concert halls, meeting rooms, and other places where silence is appreciated and given a lot of importance. Mosques are example for the places were mobile jammer would be a great solution.

Although mosques politely asks people to disable their mobile phone during the prayer, some people tend to forget to do so and the ringing phone of their mobile phone become very annoying specially during the praying time. Thus in such cases Signal Jamming will be beneficial. In section II Literature survey and objectives are discussed. Furthermore in section III, IV, V, VI Proposed system and Methodology, Results and Discussions, Future Scope and Conclusions are discussed. At the end References are mentioned.

## LITERATURE SURVEY AND OBJECTIVE

### LITERATURE SURVEY

The paper Dual Band Mobile Jammer for GSM 900 & GSM 1800, 2008 by Ahmed Sudqi Hussein Abdul-Rahman Ahmad Nasr Raja Mohammad presents the design, implementation, and testing of a dual-band cell-phone jammer. This jammer works with GSM 900 and GSM 1800 simultaneously. This project went through two phases and among the two phases one was studying the GSM-system to find the best jamming technique, establishing the system design and selecting suitable components and the second buying all the needed components, drawing the overall schematics, fabricating the PCB layout, assembling the devices, performing some measurements and finally testing the mobile jammer.

**\*Corresponding author: Saurabh Singh,**

Department of Electronics and Communication Engineering, Mumbai University, Thakur College of Engineering and Technology.

In the paper Mobile signal jammer using arduino, April 2013 by Raja Gopal MD. Imthiyaz Ur Rahmaan states that like other radio jamming, mobile jammer block mobile phone use by sending out radio waves along the same frequencies that mobile phones use. This causes enough interference with the communication between mobile phones and communicating towers to render the phones unusable. Upon activating mobile jammer, all mobile phones will indicate "NO NETWORK". Incoming calls are blocked as if the mobile phone were off and when the Mobile jammers are turned off then all mobile phones will automatically reestablish communications and provide full service. Mobile jammer's effect can vary widely based on factors such as proximity to towers, indoor and outdoor settings, presence of buildings and landscape, even temperature and humidity play an important role. The paper Cellular Signals Jamming System in 2G And 3G, April 2014 by Shantanu Krishna Mahato, C.Vimala states and discusses the design and development of GSM Mobile jammer and aims to present a solution for the problems that occur through the cell phone. The main concept of jamming is the releasing of same frequency which is using by mobile service provider with noise so user equipment gets destruct. In this paper, we have to jam a cell phone and for that we are developing a device that broadcasts on the correct frequencies. Although different cellular systems process signals differently, all cell-phone networks use radio signals that can be interrupted.

## OBJECTIVE

To prevent cellular phone from receiving and transmitting the mobile signals to the base station. To block all kinds of mobile phones ringing sound at all places such as Banks, libraries, movie theaters, meeting rooms and others so as to maintain the required silence in respective place. Effectively disable mobile phones within the defined regulated zones without causing any interference to other communication. Direct communication is made with the GSM provider to block the service.

## PROPOSED SYSTEM AND METHODOLOGY

### HARDWARE UTILIZATION

The Hardware utilized in this project are Transistors, Capacitors, Inductor and GSM antenna.

### GAP ANALYSIS

In order to determine which technologies needed to be developed and which technologies are available to be adopted, a gap analysis was conducted. This gap analysis focuses on several desired capabilities of the final product. If a capability can be acquired without conflicting with another capability using a currently available technology, then there is no gap. If there is no such technology, then one such technology must be developed in order to attain the desired set of capabilities. These gaps between available and unavailable technologies must be understood before system development begins in order to determine the feasibility of the project. The aim of this project is to build the system which will prevent mobile phones from receiving or Transmitting signals with the base stations. It is a device used to prevent mobile phones from receiving or transmitting signals with the base stations. In this paper, we have to jam a cell phone and for that we are developing a device that broadcasts on the correct frequencies.

Although different cellular systems process signals differently, all cell-phone networks use radio signals that can be interrupted. GSM, used in digital cellular and PCS based systems, operates in the 900-MHz, 1800-MHz and WCDMA 2100 bands in Europe and Asia and in the 1900-MHz band in the United States. Jammers can broadcast on any frequency and are effective against WCDMA, GSM and DCS. This project discusses the design and development of GSM Mobile jammer and aims to present a solution for the problems of occur through the cell phone. The main concept of jamming is the releasing of same frequency which is using by mobile services.

## PROBLEM DEFINITION

Cell phones are everywhere these days and its great to be able to call anyone at any time. Unfortunately, class room, shopping malls and Temples, Libraries, Hospitals all suffer from the spread of cell phones because not all cell-phone users know when to stop talking and to make sure that the use of mobile phones are eliminated when it demands so the signal jammer will an important role. The wide use of mobile phones could create some problems as the sound of ringing becomes annoying or disrupting. This could happen in some places like conference rooms, law courts, libraries, lecture rooms which will indeed be annoying and not a pleasant sight.

## METHODOLOGY

Jamming devices overpower the cell phone by transmitting a signal on the same frequency as the cell phone and at a high enough power that the two signals collide and cancel out each other. Cell phones are designed to add power if they experience low-level interference, so the jammer must recognize and match the power increase from the phone. Cell phones are full-duplex devices, which mean they use two separate frequencies, one for talking and one for listening simultaneously. Some jammers block only one of the frequencies used by cell phones, which has the effect of blocking both. The phone is tricked into thinking that there is no service because it can receive only one of the frequencies. Less complex devices block only one group of frequencies, while sophisticated jammers can block several types of networks at once to head off dual-mode or tri-mode phones that automatically switch among different network types to find an open signal.

Some of the high-end devices block all frequencies at once and others can be tuned to specific frequencies. To jam a cell phone, all you need is a device that broadcasts on the correct frequencies. Although different cellular systems process signals differently, all cell phone networks use radio signals that can be interrupted. GSM, used in digital cellular and PCS-based systems, operates in the 900-MHz and 1800-MHz bands in Europe and Asia and in the 1900-MHz band in the United States. Jammers can broadcast on any frequency and are effective against AMPS, CDMA, TDMA, GSM, PCS, DCS, iDEN and Nextel systems. Old fashioned analog cell phones and today's digital devices are equally susceptible to jamming. Disrupting a cell phone is the same as jamming any other type of radio communication. A cell phone works by communicating with its service network through a cell tower or base station. Cell towers divide a city into small areas, or cells. A jamming device transmits on the same radio frequencies as the cell phone that is 900MHz disrupting the

communication between the phone and the cell-phone base station in the town. It is called a "denial-of-service attack". The jammer denies service of the radio spectrum to the cell-phone users within range of the jamming device. Older jammers sometimes were limited to working on phones using only analog or older digital mobile phone standards. Newer models such as the double and triple band jammers can block all widely used systems (AMPS, iDEN, GSM, etc) and are even very effective against newer phones which hop to different frequencies and systems when interfered. As the dominant network technology and frequencies used for mobile phones vary worldwide, some work only in specific regions such as Europe or North America. The power of the jammer's effect can vary widely based on factors such as proximity to towers, indoor and outdoor settings, presence of buildings and landscape, even temperature and humidity play an important role.

### Mobile Jamming and Disablers Techniques

There are different approaches to prevent mobile phones from ringing in specific areas. The main five approaches used or being developed are described in RABC Mobile & Personal Communications Committee's and are summarized in this section:

#### Type A Device: JAMMERS

In this device we overpower cell phone's signal with a stronger signal. This type of device comes equipped with several independent oscillators transmitting jamming signals capable of blocking frequencies used by paging devices as well as those used by cellular/PCS systems control channels for call establishment. When active in a designated area, such devices will prevent all pagers and mobile phones located in that area from receiving and transmitting calls. This type of device transmits only a jamming signal and has very poor frequency selectivity, which leads to interference with a larger amount of communication spectrum than it was originally intended to target

#### Type B Device: INTELLIGENT CELLULAR DISABLERS

This device also called "Intelligent Cellular Disablers devices", and it does not transmits an interfering signal on the control channels. The device basically works as a detector, and it is capable to communicate with the cellular base station. When the 4 device detects the presence of a mobile phone in the room then a prevention of authorization of call establishment is done by the software at the base station. The device signals the base station that the target user is in a room and thus commands it to do not establish the communication. Messages can be routed to the user's voice- mail box, if the user subscribes to a voice- mail service. This process of detection and interruption of call establishment is done during the interval normally reserved for signalling and handshaking. This device can recognize emergency calls and also can allow specific pre-registered users to use their mobile phones for a specified duration.

#### Type C Device: INTELLIGENT BEACON DISABLERS

This device also called "Intelligent Beacon Disablers" as in the type "B" device it does not transmit an interfering signal on the control channels.

When the device is located in a specific room, functions as a beacon and any compatible terminal is ordered to disable its ringer or disable its operation. In the coverage area of the beacon only terminals which have a compatible receiver would respond and this should be built on a separate technology from cellular/PCS. The Bluetooth technology is one of its examples. Also the handset must re-enable its normal function as it leaves the coverage area of the beacon.

#### Type D Device: DIRECT RECEIVE & TRANSMIT JAMMERS

This jammer is similar to type "A" but with a receiver, so that jammer is in the receiving mode and when the device detects the presence of a mobile phone in the room, it will intelligently choose to interact and block the cell phone by transmitting jamming signal. This jam signal would only stay on as long as the mobile continues to make a link with the base station or else there would be no jamming transmission. Also this technique has an added advantage over Type B that no added overhead time or effort is spent negotiating with the cellular network.

#### Type E Device: EMI SHIELD PASSIVE JAMMING

This technique is using EMI suppression techniques to make a room into something which is known as Faraday cage. With current advances in EMI shielding techniques and commercially available products one could conceivably implement this into the architecture of newly designed buildings for so called quiet-conference rooms. Emergency calls would be blocked unless there was a way to receive and decode the Emergency Call transmissions, pass by coax outside the room and retransmitted. This passive configuration is currently legal in most countries for any commercial or residential location. However some building may not allow this type of construction.

### CIRCUIT DIAGRAM

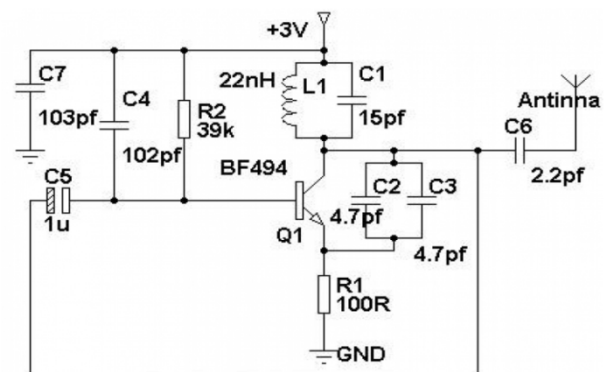

Fig.1 Connection circuit

## RESULTS AND DISCUSSION

### SIGNIFICANCE

The project of Signal Jamming will make sure that no disturbance is created in the area where silence is appreciated. It stops the transmission and reception of signals in specific region and boundaries and does not interfere with the external boundary.

## RESULTS



**Fig.2 Connection and respective mounting for the project**

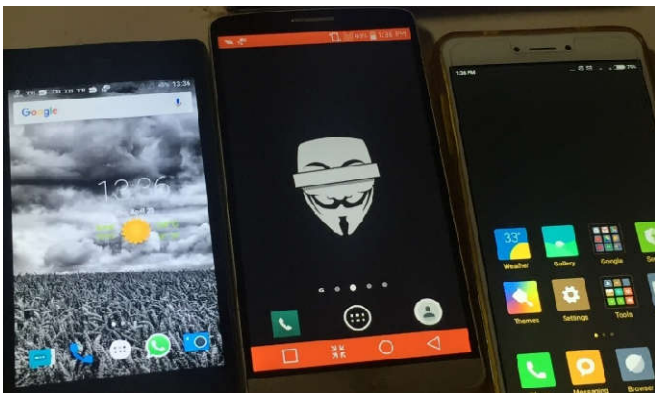

**Fig.3: Signals Jammed (no signal on mobile)**

## FUTURE SCOPE

Cell phones are full-duplex devices, which mean they use two separate frequencies, one for talking and one for listening simultaneously. Some jammers block only one of the frequencies used by cell phones, which has the effect of blocking both. The phone is tricked into thinking there is no service because it can receive only one of the frequencies. The scopes of the Jammer are that it can restrict the mobile phone signal which 30m~70m & up in diameter and 200 meters far from the transmitting station. It only shields mobile phone signals, but has no influence on other electronic equipments, audio equipments and human bodies. It is easily installed and the connector plugs is the only one what is needed to install. It saves the electric energy. To jam a cell phone, a device that broadcasts on the correct frequencies is needed. Although different cellular systems process signals differently, all cell-phone networks use radio signals that can be interrupted. The jammer's effect can vary widely based on factors such as proximity to towers, indoor and outdoor setting, presence of buildings and landscapes, even temperature and humidity play a role.

## Conclusion

In this project a GSM-900 Mobile Jammer was designed and built. The project was tested against the two GSM-900 Networks and has proven success with average range of 10 m. Due to power supply variation with load current, so to improve the jammer a more stable power supply should be designed for robust operation of the device. Also the power supply was not capable to deliver the needed current for the power amplifier and the reason for the actual coverage range of the device was not the same as designed for. Testing in different location shows the dependence of the jamming range on the signal strength. For instance in low GSM coverage area the jamming range exceeds 20 m. In general the jamming attack was protected by network signal power, and having large power jamming device the GSM network will be jammed for sure and from this observation it can be concluded that the protection against jamming attack in the GSM system was very weak and couldn't withstand the simplest jamming techniques. The main disadvantage of the mobile jammer is that the transmission of the jamming signal which is prohibited by law in many countries, for instance the fines for this offense can be very high. Despite the legal issues the transmission of high power signal may affect the operation of some critical devices, such as hearing impairment hardware solution. These disadvantages will constrain the use of mobile jammer.

## REFERENCES

- "Frequency planning and frequency coordination for the gsm 900, gsm 1800, e-gsm and gsm-r land mobile systems (Except direct mode operation (DMO) channels)" by Working Group Frequency Management"(WGFM).
- Ahmed Jisrawi, "GSM 900 Mobile Jammer", undergrad project, JUST, 2006
- Horowitz, P.; Hill, W., the Art of Electronics, 2nd. Ed, Cambridge University Press.
- <http://www.just.edu.jo/~nihad/files/mat/591/Jammer%20Final%20Report.pdf>
- [http://www.mumor.org/public/publications/ISCAS\\_2004\\_MuMo\\_Receiver.pdf](http://www.mumor.org/public/publications/ISCAS_2004_MuMo_Receiver.pdf)
- John Scourias, Overview of the Global System for Mobile Communications.
- Mobile & Personal Communications Committee of the Radio Advisory Board of Canada, "Use of jammer and disabler Devices for blocking PCS, Cellular & Related Services.
- Pozar, D., Microwave Engineering, John Wiley and Sons, 2005
- Siwiak, K., Radiowave Propagation and Antennas for Personal Communications, Artech.

\*\*\*\*\*