



DESIGN AND FABRICATION OF A SIMPLE FOUR POINT PROBE SYSTEM FOR ELECTRICAL CHARACTERIZATION OF THIN FILMS

J.O. Agumba¹, P.M. Karimi², J. Okumu³ and W.K. Njoroge⁴

Department of Physics, School of Pure and Applied Science, Kenyatta University, Kenya. P.O. Box 43844-00100, Nairobi-Kenya

ARTICLE INFO

Article History:

Received 18th April, 2011
Received in revised form
12th May, 2011
Accepted 19th June, 2011
Published online 16th July 2011

Key words:

Magnetron,
Sputtering,
Thin film,
Van der Pauw set-up,
LabVIEW,
Interfacing.

ABSTRACT

The electrical characteristics of semiconductor thin films are of great practical interest in microelectronics industry hence the need to measure these parameters in a cheaper and faster manner possible. In this study, we report on design and fabrication of a cheap, simple and portable computer-aided four point probe system for thin film sheet resistivity measurement. The designed system has been used to measure sheet resistivity of Cu₂O semiconductor thin films prepared at different sputter conditions by DC reactive magnetron sputtering technique. With the Van der Pauw set-up and a square symmetry adopted, sheet resistivity of Cu₂O thin films at room temperature of 23°C was found to be 55.65 Ω cm when measured using the system. However, as the samples were exposed to temperature rise, the sheet resistivity was found to decrease and was at its minimum value of 29.67 Ω cm at 170°C. The sheet resistivity of Cu₂O thin films were further found to increase with increase in sputter pressure during film preparation. Films deposited at sputtering pressure of 1.8x10⁻² mbar had sheet resistivity of 33.64 Ω cm and this increased to 62.23 Ω cm for films deposited at higher sputtering pressure of 2.4x10⁻² mbar.

© Copy Right, IJCR, 2011, Academic Journals. All rights reserved

INTRODUCTION

Thin film semiconductors play a crucial role in hi tech industries with major exploitation in microelectronics, communication and optoelectronics [1]. Cu₂O thin films being semiconductors offers a wide range of promising applications such as low cost photovoltaic cell fabrication due to their high absorption coefficient in the visible range of 0.35-0.80 μm and low band gap of 2.00 eV. Their other application areas include use in electro-chromic coatings, catalytic applications and in high-T_c superconductors. This semiconductor thin film has attracted attention for many years due to its cuprite structure, its connection with Bose-Einstein Condensation (BEC) of excitons, its stoichiometric deviations arising from preparation methods and parameters, ease of preparation, non-toxic nature and abundance [2]. Nevertheless, the progress of its application has been limited by difficulties associated with preparation of high quality films since many of its preparation methods results in co-deposition of phases of Cu, Cu₂O and CuO [3]. Thin film sheet resistivity which is a surface inherent resistance to flow of current determines the surface impurity content hence doping level and electron mobility [4]. This in turn affects its component's capacitance, the series resistance and threshold voltage.

The knowledge of sheet resistivity of semiconductor thin films and of Cu₂O in particular is of great practical importance for the fabrication of electronic components such as rectifier diodes, transistors, photovoltaic cells and humidity sensors since this parameter affects their performance in these applications [5]. There is hence the need to measure this parameter in an easy, faster and accurate manner possible. However, the measurement of thin film sheet resistivity has mainly been done either by the old manual methods or by use of two point probe method which inadvertently introduces errors due to probe resistance, spreading resistance and contact resistance between probing tips and the samples [6]. In this study, an inexpensive, simpler and faster software-based technique has been designed and fabricated for electrical characterization of thin film samples and for proof of the system's workability and reliability, sheet resistivity of Cu₂O semiconductor thin films prepared at different sputtering conditions have been measured. The dependence of the sample's sheet resistivity on temperature variation and a possible deviation in the crystal lattice of the Cu₂O thin films that may arise from sample's temperature change has also been studied. With the results obtained compared to the theoretical and available experimental results, the reliability of the developed system has been tested. An interactive LabVIEW graphical software has been extensively used for

*Corresponding author: j.agumba@pwaniuniversity.ac.ke

interfacing of both SMU and the Van der Pauw device, data acquisition, data analysis and data presentation.

RELATED WORK

Four point probe

The four point probe technique dates back to 1916 when Wenner used it to measure the earth's resistivity [7]. In 1954, Valdes adopted it for semiconductor wafer resistivity measurement [8]. Today, it is widely used in the semiconductor industry to monitor production process [9]. The four point probe technique can be used to measure film thickness, but it is usually used to measure the sheet resistance of shallow layers (as a result of epitaxy, ion-implant, diffusion, evaporation or sputtering) and the bulk resistivity of bare wafers. Numerous investigations have been made on the four point probe technique and measurement of sheet resistivity of thin films which are of great relevance to this study. In a study on the method of measuring specific resistivity and Hall Effect of a disc of an arbitrary shape, a relationship between sheet resistance (R_s), sheet symmetry factor (F), correction factor (Q), current (I), voltage drop (V) and the film thickness t in SI units was developed and presented as shown in the equation below [10].

$$R_s = \frac{\pi}{\ln 2} F(Q) \left(\frac{V}{I} \right)_{Average} \Omega/\text{Square}$$

This study showed that the correction factor (Q) depends on the sheet symmetry factor (F) by the equation below.

$$\frac{Q-1}{Q+1} = \frac{F}{0.693} \operatorname{ar} \cosh \left(\frac{e^{0.693/F}}{2} \right)$$

In a study to design and develop a programmable laboratory interface systems for use in resistivity measurements, a four point probe system for sheet resistivity measurement was designed and fabricated. Commercial probe head being expensive and not easily available in the laboratories was designed and fabricated from easily available materials [11]. A thin film sheet resistivity measurement where a collinear symmetry has been performed [12]. Figure 1 depicts how the measurement was done.

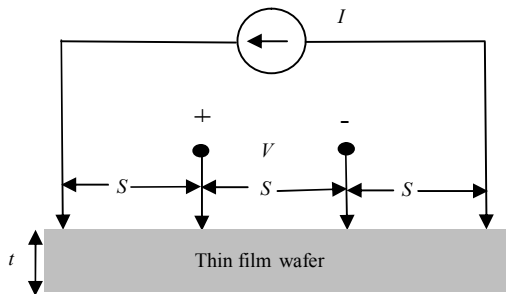

Figure 1: Schematic of collinear four point probe set-up

Here, S was probe spacing, V was voltage drop across the sample, I was current in the sample and t was the film thickness. In this study, the thin film sheet resistivity was given by equation below.

$$\rho_s = \frac{\pi}{\ln 2} \times \frac{V}{I} \times t \times k$$

Effect of sputtering parameters on Cu_2O thin films

The effect of amount of oxygen flow into a sputter chamber during Cu_2O DC reactive sputter deposition was studied and was found to affect sheet resistivity of thin film deposited [13]. The study showed that there is a sharp decrease in resistivity of the thin films with increase in oxygen flow into the chamber due to reduction of $\text{Cu}/\text{Cu}_2\text{O}$ interface roughness. This also suggested increase in the crystal crystallinity of the film formed. It was realized that the electrical resistivity of the films decreased from $4.6 \times 10^1 \Omega \text{ cm}$ to $1.0 \times 10^1 \Omega \text{ cm}$ with the increase of substrate bias voltage from 0 to -45 V and thereafter it increased to $1.6 \times 10^1 \Omega \text{ cm}$ at a higher bias voltage of -80 V [14]. The effect of sputtering pressures on structural, optical and electrical properties of DC reactive magnetron sputtered Cu_2O thin films was studied. The electrical resistivity of the films was found to increase from $1.1 \times 10^1 \Omega \text{ cm}$ to $3.2 \times 10^3 \Omega \text{ cm}$ with increase in sputtering pressure from 1.5 Pa to 8.0 Pa [15]. The effect on annealing on the resistivity of Cu_2O solar cells has also been investigated and found to be a function of the power output of such solar cells. Results revealed that the annealing of Cu_2O samples improves the cell's output performance as compared to that of unannealed samples by about 36%. With oxidation varied with temperature from 950 °C to 1050 °C, the resistivity varied from 501.04 $\Omega \text{ cm}$ to 498.14 $\Omega \text{ cm}$. Annealing was found to be a great factor in varying the electrical resistivity of the Cu_2O thin films [16]. The effect of sputtering power on electrical properties of DC reactive magnetron sputtered Cu_2O thin films has been investigated. The films formed at low sputtering power of 0.38 Wcm^{-2} showed high electrical resistivity of $4.3 \times 10^5 \Omega \text{ cm}$ and as the sputtering power was increased to 1.08 Wcm^{-2} , the electrical resistivity of the films reduced to 46 $\Omega \text{ cm}$.

MATERIALS AND METHODS

Probe head design and fabrication

The fabrication of probe head was done using Perspex sheets, steel bolts, aluminum rods, spiral springs, metallic tubes, fastening screws, connecting cables and crocodile clips. Four holes 0.5 cm apart were drilled on a Perspex sheet measuring 12 cm by 12 cm and steel bolts inserted in the four holes ensuring that the spacing between them is equal and maintained. Four spring loaded metallic tubes were connected to the four aluminum rods with sharp ends to act as probing tips on one side and to the steel screws on the other end. The Perspex sheet mounted with the probe tips was able to move up and down about another Perspex sheet stage for holding the thin film whose sheet resistivity is to be measured when tapping screws were loosened.

Van der Pauw device design and fabrication

An electronic switching device was designed and fabricated to perform switching of probe tips on the thin samples as outlined by the Van der Pauw set-up. This was accomplished by use of a transistor driven 14-pin relay switch controlled by a computer via printer port (LPT1). Figure 2 shows the Van der Pauw switching device designed in ExpressSCH software.

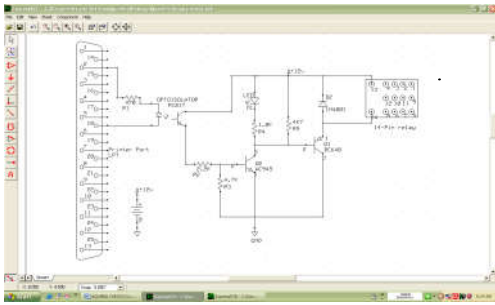

Fig. 2: Design diagram of relay switching device circuit

Devices interfacing

For automation of measurements, there was need for interaction between the computer, the Keithley SourceMeter unit and the Van der Pauw switching device. The interfacing was done to provide automation of measurements by enhancing data flow between the computer and the peripherals. There was hence a full control of the peripheral devices by the computer. This was done in an interactive LabVIEW environment using VISA VIs. The SMU was interfaced to a PC via serial port (RS-232 port). The block diagram below shows the code of the SMU interface to PC using VISA VIs.

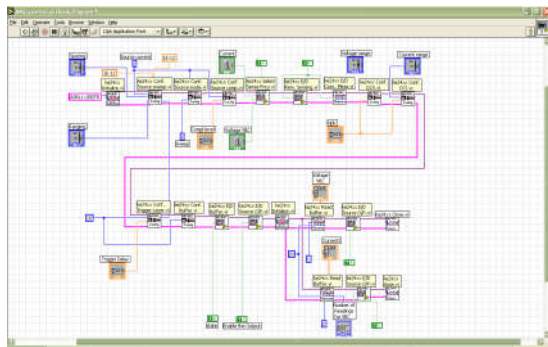

Fig. 3: Block diagram of SMU interface to Computer via RS-232 port.

The Van der Pauw switching device was interfaced to a PC via a LPT 1 port. Figure 4 illustrates the block diagram of how this was achieved using inport.vi and outport.vi functions.

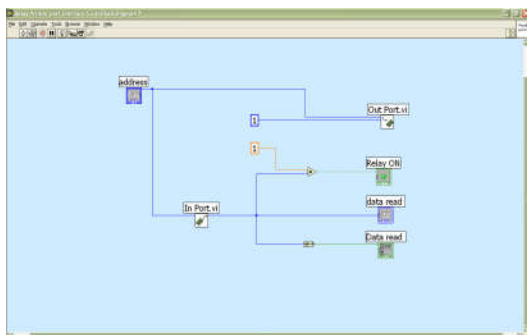

Fig.4: Block diagram of Van der Pauw device interface to computer

The photograph in figure 5 illustrates the fabricated system accompanied with the controlling computer and the Lindberg tube furnace.

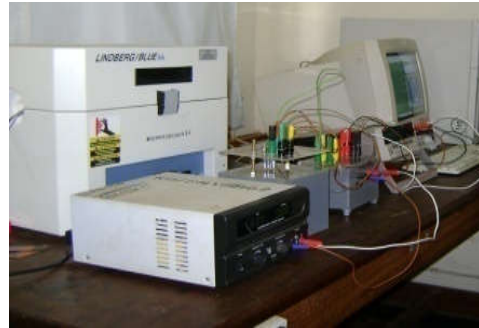

Fig. 5: Photo of the fabricated system

Thin Film deposition

The Cu₂O films used to illustrate the workability and reliability of the designed and fabricated system were deposited on the glass substrates by DC reactive magnetron sputtering method using Edward's AUTO 306 vacuum coater. The sputter conditions were as depicted in the table below.

Table 1. Sputtering conditions during Cu₂O thin film test samples deposition

Sputtering target	Pure Copper
Sputtering to substrate distance	65 mm
Base Pressure	2.5x10 ⁻⁶ mbar
Oxygen partial pressure	2x10 ⁻⁴ mbar
Sputtering pressure	1.9x10 ⁻² mbar
Substrate temperature	473 K
Cathode Current	200 mA
Sputtering Power	200 W

One hour after completing sputtering and power switched off, the deposited Cu₂O thin film samples were removed for I-V measurement and subsequent sheet resistivity measurements. In order to investigate the effect of sputtering pressure on thin film sheet resistivities using the developed system, seven samples were deposited at different sputtering pressures of 1.8 Pa, 1.9 Pa, 2.0 Pa, 2.1 Pa, 2.2 Pa, 2.3 Pa and 2.4 Pa. The other parameters such as base pressure, oxygen partial pressure and sputtering power were maintained as outlined in Table 1. After the deposition, four point probe technique was used to measure the sheet resistivity of the Cu₂O semiconductor thin film samples. With a symmetrical square geometry adopted, the four leads from the designed probe head were connected to Keithley SourceMeter via the switching device as per the Van der Pauw set-up for Voltage and Current measurements. The schematic diagram of four-point probe resistivity measurement is depicted in figure 6. Current of 1.0 x 10⁻¹⁰ A was applied through the contacts A and B and the potential drop V_{DC} across the contacts D and C measured. With switching of probe tips on the sample done by the developed switching device, the same amount of current (I) was then applied through the contacts A and D and the potential drop V_{BC} across the contacts B and C measured. With the thin films sheet thickness measured using stylus-method profilometry, the values of current, measured voltage drops and film thickness were used

to compute sheet resistivity using equation below by the developed LabVIEW software.

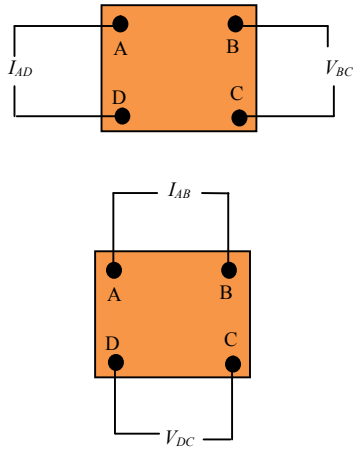

Fig. 6: Schematic of four point probe phenomenon

$$R_s = \frac{\pi}{\ln(2)} f(Q) \frac{V_{BC} + V_{DC}}{2I} \left[\frac{\Omega}{\text{Square}} \right]$$

Where f and Q are the Van der Pauw symmetry and correction factors respectively. The sheet resistivity measurement of the test sample was first performed at room temperature (23°C) and then at varied temperatures by placing the sample in a Lindberg/Blue Tube Furnace TF55035A model. Sheet resistivities of thin films deposited at different sputtering pressures were then measured using the technique by repeating the above procedures.

RESULTS AND DISCUSSIONS

From the I and V measurements, the test sample of thickness 99.27 nm was found to have a sheet resistivity of 55.6548 Ω cm at room temperature as shown in the front panel below.

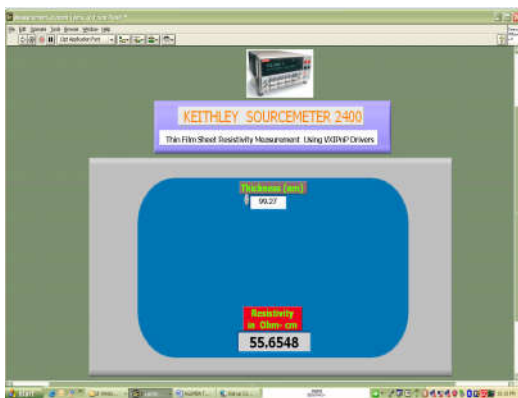

Fig. 7: Front panel showing the display of sheet resistivity measured

When sheet resistivity of the thin film was plotted as a function of temperature, the graph in figure 8 was obtained. As depicted in the graph, it is seen that the surface sheet resistivity at room temperature of 23 °C was 55.0837 Ω cm. As the sample temperature was increased above room

temperature, the sheet resistivity dropped and was at its minimum value of 29.6691 Ω cm at a temperature of 170 °C.

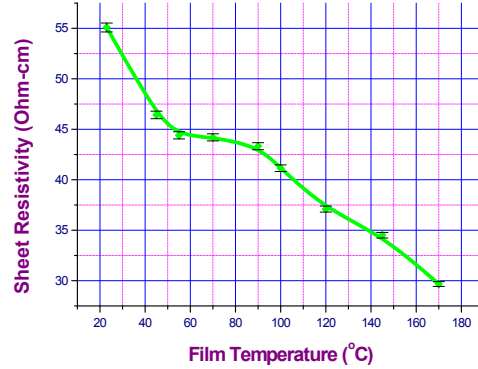

Fig. 8: Graph of Sheet Resistivity (Ω cm) against Temperature (°C)

Crystal defects could result during the thin film deposition and the drop in sheet resistivity from 55.0837 Ω cm to 29.6691 Ω cm with temperature rise from room of 23 °C to temperature of 170 °C could be attributed to healing of these crystal defects. Again, high film sheet resistivity at room temperature could be attributed to polycrystalline phases of Cu, Cu₂O and CuO present in the film. High temperatures could have increased the crystallinity of the film with a single phase of Cu₂O of higher carrier mobility formed. The results of sheet resistivities of seven samples prepared at sputtering pressures of 1.8 Pa, 1.9 Pa, 2.0 Pa, 2.1 Pa, 2.2 Pa, 2.3 Pa and 2.4 Pa measured using the system are depicted in figure 9.

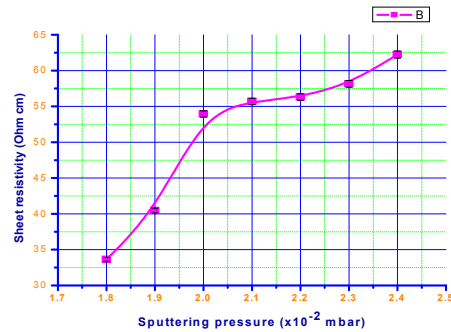

Fig. 9: Graph of Sheet Resistivity (Ω cm) against Sputtering Pressure (mbar)

As depicted in the graph above, the sheet resistivities of the thin films increased from 33.6363 Ω cm to 62.2341 Ω cm with increase with sputtering pressure from 1.8x10⁻² mbar to 2.4x10⁻² mbar. The low sheet resistivity at lower sputtering pressures may be attributed to high carrier mobility and carrier concentration since film's crytallinity is increased. The high sheet resistivity at higher sputtering pressures may be due to the amorphous nature of the films with the phases of Cu, Cu₂O and CuO present in the films.

CONCLUSIONS

A simple, cheap, portable and computer-aided four point probe system required for sheet resistivity measurements has been designed and fabricated. A probe head and a Van der Pauw switching device have been fabricated. LabVIEW graphical

software has been used to interface a SourceMeter 2400 and the switching device via a serial (RS-232) port and printer (LPT1) port, respectively. LabVIEW VIs have also been developed for data acquisition from the peripherals, data analysis and display by the computer. The software based system has been used to measure sheet resistivity of a test sample of DC sputtered cuprous oxide thin films both at room temperature and at different temperatures in order to prove the system's workability and reliability. At room temperature of 23 °C, the sheet resistivity was found to be 55.6548 Ω cm. As the temperature of the sample was raised from 23 °C to 170 °C, the film sheet resistivity decreased from 55.0837 Ω cm to 29.6691 Ω cm. The behavior of the measured sheet resistivity has been found to agree with the theoretical and experimental values with the decrease in sheet resistivity with rise in temperature being attributed to healing of crystal defects which could have arose during the thin film deposition [15].

The sputtering pressure in the sputter coater during the thin film deposition has also been found to determine sheet resistivity of the thin films. As the sputtering pressure was increased from 1.8×10^{-2} mbar to 2.4×10^{-2} mbar, there was corresponding increase of sheet resistivity of the thin films from 33.6363 Ω cm to 62.2341 Ω cm. Films formed at lower sputtering pressures had high crystallinity with high carrier mobility and carrier concentration while films formed at higher sputtering pressures were more amorphous in nature with the phases of Cu, Cu₂O and CuO present in the films. This was attributed to a more porous films formed at high sputtering pressures [15]. From the measurements of sheet resistivity of the test sample, films at varied temperatures and films prepared at different sputtering pressures, we can conclude that the designed and fabricated four point probe system offers a reliable solution for use in thin film sheet resistivity measurements.

REFERENCES

- [1] Ohring, M. (1992). The Material Science of thin films, Academic Press, United Kingdom, Pp. 34-79.
- [2] Sivasankar, R. A., Hyung-Ho, P., Sahadeva, R., Sarmab, K. U., Sreedhara, R. (2008). Effect of sputtering power on the physical properties of dc magnetron sputtered copper oxide thin films. *Materials Chemistry and Physics*. 110 (5): 397–401.
- [3] Balamurugan, B., Mehta, B.R. (2001). Optical and structural properties of nanocrystalline copper oxide thin films prepared by activated reactive evaporation. *Thin Film Laboratory*. 2(14): 1-5.
- [4] Maria, P., Gutierrez, S., Haiyong, I., Patton, J. (2002). Thin Film Surface resistivity. *In partial fulfillment of course requirements for Mate 210*. Experimental Methods in material Engineering, USA.
- [5] Sze, S. (1981). Physics of semiconductor devices. 2nd edition. John Willy & Sons, pp. 332-361. New York, USA, Pp. 56-67.
- [6] Schroeder, D. K. (1998). Semiconductor Material and Device Characterization, 2nd edition, John Wiley and Sons, New York, USA, Pp. 217-342.
- [7] Wenner, F. (1916). A method of measuring Earth Resistivity. *Bulletin of the Bureau of Standard*. 12: 469-4
- [8] Valdes, L. (1954). Resistivity Measurement of germanium for transistors. *Proc. IRE*. 42: 420-427.
- [9] Smits, F.M. (1958). Measurement of sheet resistivity with the four point probes. *Bell System Technical Journal*. 37 (1): 711-718.
- [10] Van der Pauw, L.J. (1958). A method of measuring specific resistivity and Hall Effect of a disc of arbitrary shape. *Philips Technical Review*. 20: 220-224.
- [11] Owade, M.O. (1998). Design and development of a programmable interface system with illustrative use in resistivity-temperature experiment, *MSc. Thesis, Kenyatta University*. Kenya.
- [12] Bautista, K. (2004). Thin film deposition, 2nd edition, University of Texas at Dallas, Erik Jonsson School of Engineering, USA, Pp. 67-120.
- [13] Toney, F., Walter, L., Emily, L., Wen-Y, L., Jonathan, D., Lawrence, C., Jonathan, H. (2003). *Applied Physics Letter*. 89: 11-20.
- [14] Reddy A.S., Rao, G. V., Uthanna, S., Reddy, P. S. (2005). Influence of substrate bias voltage on the properties of magnetron sputtered Cu₂O films. *Physica B*. 370 (9): 29–34.
- [15] Sivasankar, R. A., Venkata, R. G., Uthanna, S., Sreedhara, R. P. (2007). Properties of dc magnetron sputtered Cu₂O films prepared at different sputtering pressures. *Applied Surface Science*. 253: 5287–5292.
- [16] Onimisi, M.Y. (2008). Effect of annealing on the resistivity of copper (I) oxide solar cells. *International Journal of Physical Sciences*. 3 (8): 194-196.
